

DESCRIPTION OF THE  
AMS 02  
AIR MONITORING SYSTEM

BITT Technology-A GmbH.  
Wienerstraße 70  
A-2104 Spillern  
Tel.: 0043/ 2266/ 80216  
Fax.: 0043/ 2266/ 80216 12  
[www.bitt.at](http://www.bitt.at)  
[office@bitt.at](mailto:office@bitt.at)

AMS02 MANUAL

V. 2.2  
08/10/2008

|          |  |           |
|----------|--|-----------|
| <b>1</b> | <b>DESCRIPTION OF THE AMS02</b>  | <b>3</b>  |
| 1.1      | INTRODUCTION   | 3         |
| 1.2      | MAIN TECHNICAL PARAMETERS  | 4         |
| <b>2</b> | <b>SCHEME</b>  | <b>5</b>  |
| <b>3</b> | <b>SET-UP</b>  | <b>6</b>  |
| 3.1      | SAMPLING AND MEASURING UNITS   | 6         |
| 3.2      | ACTUATING AND OTHER DEVICES  | 6         |
| <b>4</b> | <b>OPERATION</b>   | <b>9</b>  |
| 4.1      | INSTALLATION   | 9         |
| 4.2      | POSITIONING  | 9         |
| 4.3      | LOADING THE FILTERS  | 9         |
| 4.4      | START-UP   | 9         |
| 4.5      | BACKGROUND MEASUREMENTS  | 10        |
| 4.6      | SEQUENCE OF NORMAL OPERATION   | 10        |
| 4.7      | SEQUENCE OF OFF-NORMAL OPERATION   | 11        |
| 4.8      | MEASUREMENT OF SELECTED SAMPLES IN THE MEASURING POSITION (“EXTRA” MODE) | 11        |
| <b>5</b> | <b>DATA EVALUATION PROCEDURES</b>  | <b>11</b> |
| 5.1      | GAIN TEST  | 11        |
| 5.2      | BACKGROUND MEASUREMENTS  | 12        |
| 5.3      | CONTINUOUS SAMPLING IN NORMAL AND OFF-NORMAL OPERATIONAL MODES           | 13        |
| 5.4      | GAMMA SPECTROMETRY   | 19        |
| <b>6</b> | <b>SENSITIVITY</b>   | <b>23</b> |
| <b>7</b> | <b>APPENDIX</b>  | <b>24</b> |
| 7.1      | THE AMS-02 CONTROL SOFTWARE  | 24        |
| 7.2      | COMMUNICATIONS SOFTWARE  | 24        |
| <b>8</b> | <b>DETAILED DESCRIPTION OF MAINTENANCE</b>                               | <b>25</b> |
| 8.1      | MAINTENANCE  | 25        |
|          | DOCUMENT RELEASE   | 28        |

# 1 Description of the AMS02

## 1.1 Introduction

The hazards related to the application of nuclear energy should be minimised through proper safety facilities, still environmental monitoring and warning system are to be installed in order to assist the enforcement of protective measures for the population. The most important task of an air monitoring system is to give an alarm signal in the shortest time possible, when the radioactivity in the monitored area exceeds the natural level.

Resulting mostly from nuclear accidents or explosions, artificial radionuclides of various elements can be released into the atmosphere. The most mobile ones are the noble gases (Xe, Kr) and volatile elements (I, Cs and some others). Warning levels can be established either on the measurement of external dose rate primarily due to gamma-radiation from a radioactive plume ("skyshine radiation") or from contaminated ground surface or on the measurement of radiocontamination adhered to floating aerosol particulates. In special cases, the first warning signal may also be based on monitoring radioactivity of surface waters.

As aerosol filters coupled to air pumps are capable of accumulating particulates from large volumes of air onto a small surface, their radioactive content can be determined with good measuring efficiency thus allowing advantageously low detection and warning levels.

The aerosol measuring system AMS-02 applies two consecutive static filters, the first one for aerosol particles and a second planar filter for molecular iodine. The presence of non-natural radioactivity on either of the filters is detected by means of alpha-, beta- and/or gamma-counting. If a warning or alarm signal is generated, a third consecutive sampling and measuring unit is connected, as the air leaving the molecular iodine filter enters an appropriate canister filled with a specific absorber in order to separate organic iodine species which would escape the first two sampling devices. Activity of this unit is measured by gamma counting. The static filter equipment is served by a manipulator from a stock of 500 filters.

## 1.2 MAIN TECHNICAL PARAMETERS

**Size:** 730 x 1280 x 1620 (2100) mm

**Weight:** approx. 415 kg

**Power:** 230 V AC / 50 Hz / 1100 VA

**Environment:** Temperature +15°C + 25°C  
Relative humidity 0 - 70 %

**Accumulated air:** Temperature -30°C + 40°C  
Relative humidity 0 - 99 %

### **Units:**

Detectors:

Version 1 :

- 2" x 2" Na(Tl) ( 3 pieces )  
resolution  $\cong$  8 % ( $^{137}\text{Cs}$  662 keV)  
peak-to-total ratio > 30 % (  $^{137}\text{Cs}$  )  
background ~ 4 cps
- PIPS 1700 mm<sup>2</sup>  
resolution  $\cong$  55 keV ( $\alpha$   $^{241}\text{Am}$ )  
 $\cong$  30 keV ( $\beta$ )

Version 2 :

- 2" x 2" Na(Tl) ( 2 pieces )  
resolution  $\cong$  8 % ( $^{137}\text{Cs}$  662 keV)  
peak-to-total ratio > 30 % (  $^{137}\text{Cs}$  )  
background ~ 4 cps
- PIPS 1700 mm<sup>2</sup>  
resolution  $\cong$  55 keV ( $\alpha$   $^{241}\text{Am}$ )  
 $\cong$  30 keV ( $\beta$ )
- Coaxial germanium detector (HP Ge)  
resolution 2.0 keV FWHM at 1.33 MeV  
relative efficiency 30% at 1.33 MeV

Controllers: Industrial PC & Microcontroller cards

Pump: Nominal flow rate ~8 (normal) m<sup>3</sup>/h

Filters: - 60 mm diameter glass fibre filter (DIN 24 184)  
- 60 mm diameter paper filter with active carbon impregnated (charcoal)  
- active carbon (charcoal) filter column

## 2 SCHEME

The equipment consists of the following units (fig.):

### Unit for continuous sampling:

1. Aerosol filter - PIPS-detector
2. Aerosol filter - NaI(Tl) detector or HPGE detector
3. Iodine filter (molecular) - NaI(Tl)-detector
4. Iodine filter (organic) - NaI(Tl)-detector

### Further units:

- Optional, Special measuring equipment
- Filter manipulator
- Racks for filters (filter stock)
- Computer and control unit
- Lead shielding
- Maintenance-free air flow pump

Figure 1.  
Functional structure of AMS02

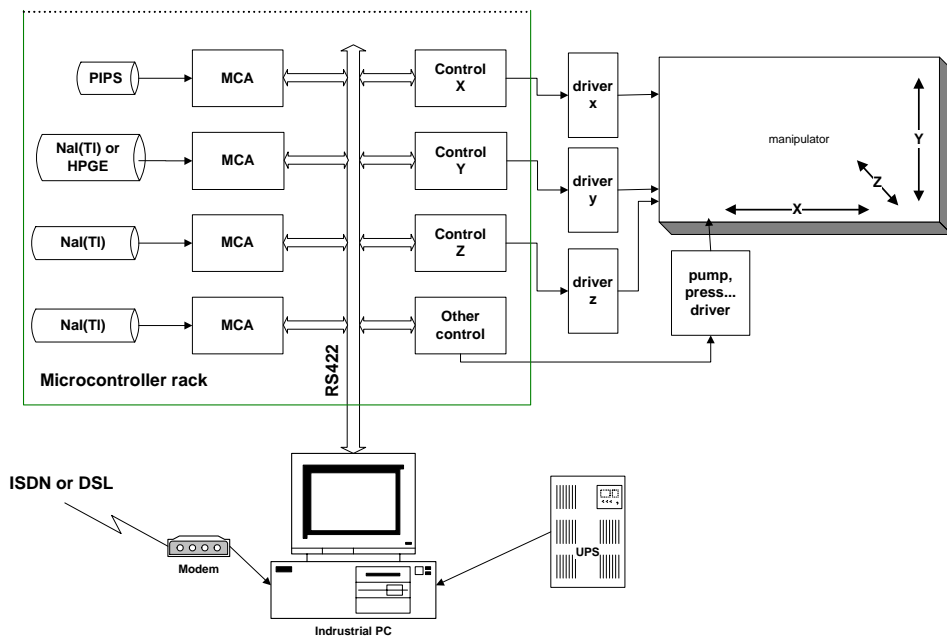
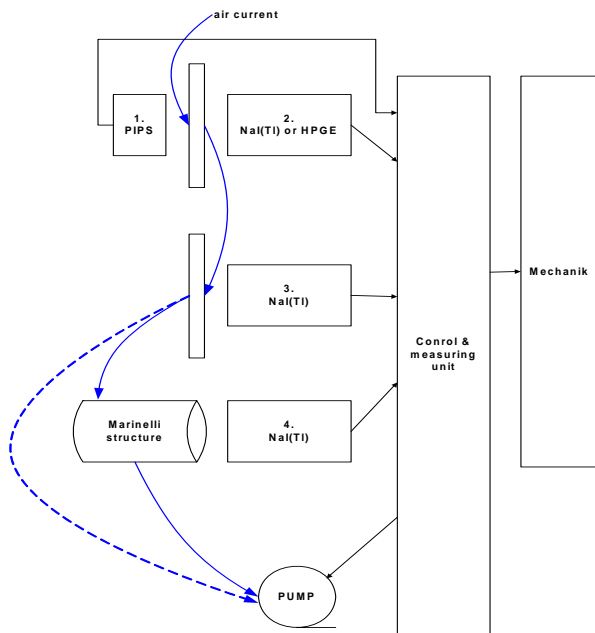

### 3 SET-UP

#### 3.1 Sampling and measuring units

##### 3.1.1 Aerosol filter facing a PIPS alpha/beta detector

- Filter: Aerosol filter (glass fibre filter Schleicher & Schüll) with a minimum filtering capacity of 99% for particulates over 0.5 µm (DIN 24 184).
- PIPS silicon detector system: 1700 mm<sup>2</sup> active surface; Resolution: 55 keV for the alpha range; 30 keV for the beta range

##### 3.1.2 Version 1: NaI(Tl) gamma scintillation detector (regular version) coupled to the rear side of the aerosol filter (see above)

NaI(Tl) scintillation detector system: crystal and photomultiplier tube of 2" (5.06 cm) diameter. 0.06 - 3 MeV energy range, gain is stabilised by heating the PM tube. Resolution: minimum 8.5 % for 662 keV <sup>137</sup>Cs photopeak.

Geometry: The gamma detector is separated from the sampling compartment by its plastic cover. Distance between detector and filter surface: maximum 10 mm.

##### 3.1.3 Version 2: HP Ge detector coupled to the rear side of the aerosol filter (see above)

Resolution: 2.0 keV FWHM at 1.33 MeV

Peak-to-total ratio 30 % relative at 1.33 MeV

(The detector is cooled through a continuously operating controlled cryostat.)

##### 3.1.4 Iodine filter facing a NaI(Tl) gamma scintillation detector

Filter: Specific impregnated iodine filter of >95% adsorption capacity for atomic or molecular iodine, comprising a thin reinforced layer of specially impregnated active carbon .

NaI(Tl) scintillation detector system: same as specified above for item 3.1.2

##### 3.1.5 Measuring position for organic iodine substances, Marinelli geometry, charcoal filter

Filter: cylindrical canister for organic-bond radio-iodine

NaI(Tl) scintillation detector system: same as specified above for item 3.1.2

#### 3.2 Actuating and other devices

##### 3.2.1 Lead shielding

The sampling and measuring slots are housed in a common lead block. The slots are separated with 30 mm thick lead walls. External gamma-ray background is thus attenuated by at least one order of magnitude.

### 3.2.2 Air flow pump

The air is pumped in through a heatable inlet tube. The inlet tube is protected against precipitate and other pollutants that may mitigate the capacity of the filters (e.g. insects). The flow volume rate can be measured, but it cannot be directly regulated. The nominal volume rate of the maintenance-free pump is 8 m<sup>3</sup>/h. The volume rate is measured indirectly by means of pressure sensor and temperature-sensor.

The volume rate is converted to "normal cubic metre" (20°C, 1 bar pressure). All activity values are applied to this value (in Bq/m<sup>3</sup>).

1. Inlet tube (heatable)
2. Aerosol filter
3. Molecular (inorganic) iodine-filter
4. Bypass
5. Organic bonded iodine-filter
6. Pump

Th Temperature-sensor

P1,P2,P3 Pressure-sensor

CPU Controlling computer

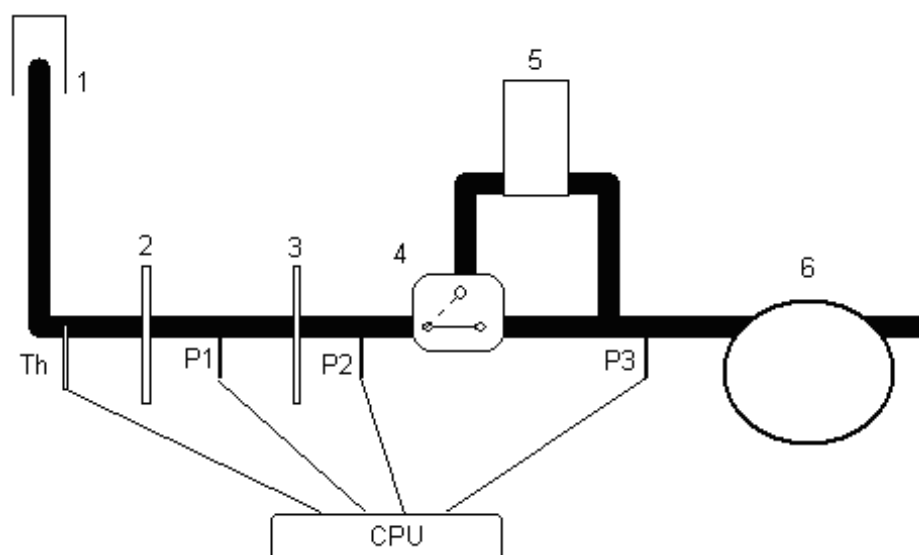

Figure 2.  
Operational structure of the electro-mechanical elements of AMS02

### 3.2.3 Manipulator

Filters are removed, stored and retrieved by means of an automatically actuated and controlled manipulator. It reaches the filter slots and the adjacent storage racks.

### 3.2.4 Storage / retrieval racks

Racks for new and used filters are positioned at an optimum distance from the lead shielding. The number of filters is determined in this way that operation of the device is ensured for at least 6 months. The aerosol filters are reusable, because the aerosol activity originating from radon daughter elements decays quickly. The longest half-life ( $T = 10.6$  h) among the daughter elements belongs to <sup>212</sup>Pb (from the <sup>220</sup>Rn series). <sup>212</sup>Pb practically diminishes within 4 days. Other reasons for the exchange of a filter are pore blocking or mechanical damage. Of course, filters which contain artificial radiocontamination

## BITT Technology Manual AMS02

(applied in off-normal-mode) cannot be used again. Therefore a databank from the filter magazine is set up.

The structure of the databank is as follows:

|                   |            |  |
|-------------------|------------|--|
| 1 Filter number   | numeric6   | (logical identification number 1...999999) |
| 2 Type            | character  | 7 (iodine or aerosol)                      |
| 3 Contaminated    | logical    | (true/false)                               |
| 4 Last meas. date | character  | 9 (last measurement yy.mm.dd.)             |
| 5 Last meas. time | character  | 5 (last measurement hh:min)                |
| 6 Usability       | character  | 7 (filter status*)                         |
| 7 Measured        | logical    | 1 ('true' under measurement)               |
| 8 Filename        | character  | 8 (data filename**)                        |
| 9 Volume          | numeric8.2 | (air-throughput of the last measurement)   |
| 10 Total volume   | numeric8.2 | (summed air-throughput)                    |

\*Filter status:

|         |   |
|---------|---|
| GOOD    | mechanically proper                       |
| HOLE    | punctured                                 |
| DUSTY   | blocked (dirty)                           |
| WORNOUT | used-up (total air volume limit exceeded) |

The statuses "HOLE" and "DUSTY" are determined from continuously measuring the differential pressure. The status WORNOUT is determined by comparing the total flow volume to a fixed total-air-throughput value. The limit is adjustable in the file "amsuser.ini".

\*\*Data filename:

These optional files are intended for spectrometric examinations in the off-line operation, they can be evaluated in the interactive mode.

Example:

| Filter_no | Type    | Contaminated | Lastm_date | Lastm_time | Usability | Measured | Filename | Volume | Total_vol |
|-----------|---------|--------------|------------|------------|-----------|----------|----------|--------|-----------|
| 96        | AEROSOL | T            | 95.04.20.  | 16:11      | GOOD      | T        | AER00096 | 40.01  | 114.01    |
| 97        | AEROSOL | F            | 95.05.25.  | 4:24       | HOLE      | F        | NO_FILE  | 5.21   | 660.69    |
| 98        | AEROSOL | F            | 95.06.27.  | 9:41       | DUSTY     | F        | NO_FILE  | 1.71   | 1283.59   |
| 99        | AEROSOL | F            | 95.05.17.  | 9:30       | DUSTY     | F        | NO_FILE  | 62.15  | 547.45    |
| 00        | AEROSOL | F            | 95.05.23.  | 2:13       | HOLE      | F        | NO_FILE  | 49.65  | 537.11    |
| 01        | AEROSOL | F            | 95.07.05.  | 4:49       | HOLE      | F        | NO_FILE  | 25.21  | 1025.33   |
| 02        | AEROSOL | F            | 95.09.02.  | 21:12      | GOOD      | F        | NO_FILE  | 116.64 | 676.67    |
| 03        | AEROSOL | F            | 95.09.03.  | 21:53      | GOOD      | F        | NO_FILE  | 119.01 | 687.74    |
| 04        | AEROSOL | F            | 95.06.30.  | 12:16      | DUSTY     | F        | NO_FILE  | 47.79  | 1223.75   |
| 05        | AEROSOL | F            | 95.07.11.  | 23:19      | HOLE      | F        | NO_FILE  | 119.30 | 1239.12   |
| 06        | AEROSOL | F            | 95.06.11.  | 4:16       | HOLE      | F        | NO_FILE  | 114.84 | 595.33    |
| 07        | AEROSOL | F            | 95.07.12.  | 23:42      | WORNOUT   | F        | NO_FILE  | 104.50 | 1090.11   |
| 08        | AEROSOL | F            | 95.07.07.  | 1:55       | HOLE      | F        | NO_FILE  | 15.02  | 988.20    |
| 09        | AEROSOL | F            | 95.07.07.  | 6:29       | HOLE      | F        | NO_FILE  | 22.70  | 905.65    |
| 10        | AEROSOL | F            | 95.07.13.  | 12:01      | WORNOUT   | F        | NO_FILE  | 103.31 | 933.08    |
| 11        | AEROSOL | F            | 95.07.08.  | 6:30       | WORNOUT   | F        | NO_FILE  | 98.71  | 912.30    |
| 12        | AEROSOL | F            | 95.07.19.  | 23:05      | WORNOUT   | F        | NO_FILE  | 103.28 | 811.98    |

### 3.2.5 Computer

Pulses from the continuously operating detectors are processed by multichannel analyser cards with an effective channel range of 1k for the PIPS and scintillation detectors and 4k for the HP Ge detector. All of these are microcontroller cards which are controlled by an industrial PC via an RS422 Interface.

The central computer performs different tasks:

- It contains and controls the data acquisition cards for the measuring detectors;
- It runs the data evaluation programs;
- It co-ordinates the operation of the manipulator and the air flow pump
- It archives the measured results and communicates with the remote control centre sending warning messages and exchanging additional information.
- It collects data from additional devices (ambient dose rate, meteorological data)
- It measures the most important status data, e.g. mains voltage, pressure drop, air volume rate etc.
- Identification of the location.

## 4 OPERATION

### 4.1 Installation

The AMS-02 system is delivered in the configuration described in Chapter [1.2](#). The system should be placed advantageously in a closed cabin or container standing in a grassy environment.

### 4.2 Positioning

The inlet tube of the air flow pump should be set to upright position. Precipitate must not enter the tube. The end of the tube should be at least 1.5 m high above the ground surface.

### 4.3 Loading the filters

An appropriate number of unused aerosol and iodine filters must be filled into the appropriate positions of the storage/retrieval rack. The rack should also contain two filter-shaped calibration standards:  $^{137}\text{Cs}$  for the NaI(Tl) detectors and  $^{137}\text{Cs} - ^{133}\text{Ba} - ^{60}\text{Co}$  mixed source for the HP Ge detector.

### 4.4 Start-up

Mains power connections of the air flow pump, the manipulator and the computer should be plugged in. The "AMS 02" program starts automatically after switching on the equipment. The main program controls the presence and status of each device then it performs detector setting control ("gain test") examinations. Both calibration sources (with activities well below the respective exemption levels) are put into the "AER" (aerosol) and "IOD" (iodine) measuring positions for 300 seconds. The program checks selected counting rates according to Chapter [5.1](#). An erroneous result with units 2 and/or 3 (see Figure 1 in Chapter 2) initiates a limited mode of the normal operation. The gain failed detector is disabled. The satisfactory operation of the PIPS/aerosol is the minimum condition.

The gain check is repeated every time filters are changed in either normal or off-normal operational modes unless it is omitted from the initialisation (nnST\_\_\_\_.i00) file containing default parameters.

## 4.5 Background measurements

Background measurements with blank filters put in the appropriate slots are performed before air pumping starts. As the external background is subject to diurnal, seasonal and meteorological changes, it is recommended to start a new cycle regularly in order to comply with them.

Background measurements take 900 seconds (default) with each detector. These measurements are repeated every time filters are regularly changed in normal operational mode. In off-normal mode or in case of an "irregular" change background should not be measured, instead, the previous set of background spectra is used until a new "normal" cycle is initiated. The duration of the background measurements can be set in the nnST\_\_\_\_.i00 initialisation file

## 4.6 Sequence of normal operation

Air pumping is started after the termination of a background measurement. The air flow enters the slot of the aerosol filter first and reaches the iodine filter subsequently. Pulses are collected for consecutive 5 minutes. Counts are evaluated for the recognition of non-natural radiocontamination accumulated on the filters (see [5.3.1](#)) In "NORMAL MODE" an IRREGULAR SPECTRUM message is generated when significant Alpha or Beta or Iodine or HP Ge high counts attributed to artificial radioactivity occur and exceed the warning threshold limits (set in nnTH\_\_\_\_.i00 initialisation file) in consecutive evaluations. The sufficient number of these consecutive evaluations triggering an "irregular spectrum" message is set in "amsuser.ini" file. Default values are 2 for exceeding "alarm" level and 3 for exceeding "warning" level. In addition to an "irregular spectrum" message a filter change is performed and the system resumes operation in "OFF-NORMAL MODE". The previously used filters are stored in the storage rack with a "Contaminated" label. If the "warning" or "alarm" conditions indicating significant amount of artificial radioactivity present on any of the filters are met in off-normal mode as well, "WARNING" or "ALARM" status is declared. The evaluating program records the volume of the processed air, so it can estimate the maximum and minimum activity concentration for a suspected contaminant. If during the one hour long "off-normal" mode there are 6 normal evaluation cycles without meeting the "warning" or "alarm" conditions (this is the default value given in amsuser.ini file), the program returns to "normal" mode otherwise "off-normal" mode is prolonged as warning/alarm status remains valid.

The spectrum taken by the HP Ge detector is not deleted and refreshed in every 5-minute measurement period, instead, it is kept and the counts of the consecutive cycles are added together. Thus, the detection limit for artificial radioisotopes is indirectly improved from cycle to cycle, because the contaminants inevitably have longer half-lives than those of the radon descendants and - in case of a low, but constant concentration in the sampled air - their intensity (that is, counts relative to the total sampling time) will remain theoretically constant while that of the "suppressing" radon descendants decrease after a certain period of time. On the other hand, this detector cannot "keep track" of the rapid changes of the radon level, leaving this task for the more appropriate PIPS detector. The regular response message of the unit with PIPS or NaI(Tl) detector attached to the aerosol filter gives an estimation of the current radon equivalent equilibrium concentration (in Bq/m<sup>3</sup>) in the atmosphere using the data obtained with the aerosol filter. The background status of the iodine filter is also indicated in the message.

After 12 - 24 hours of normal operation (the actual value is determined in the respective xxST\_\_\_\_.i00 "INI" file) the aerosol filter is changed for a new one exempt from natural radioactivity, otherwise the contribution of the descendants of the thorium-based <sup>220</sup>Rn (thoron) would build up onto the aerosol filter changing the expected pulse height distribution and increasing the possibility of a false warning. The new cycle starts with the change of the aerosol filter followed by an optional gain test and a background measurement.

The effective half-lives of <sup>238</sup>U-based and <sup>232</sup>Th-based radon descendants are about 30 minutes and 10 hours, respectively. Due to the latter, a used aerosol filter is kept decaying for at least 84 hours (7 normal sampling cycles of 12 hours) to get rid of thoron activity. Then the filter can be considered exempt from excess activity so it is reused until the flow resistance of the filter reaches a limit. Air flow rate is checked after each data evaluation. Would this test fail, a cycle-breaking "regular" filter change is performed.

## 4.7 Sequence of off-normal operation

Off-normal sequence is initiated by three consecutive warning signals or by two consecutive alarm signals, thus only minutes after the first assumed indication of non-natural airborne radioactivity. Both the aerosol and iodine samples will then be collected for only one hour, while data evaluation is performed still in every five minutes.

In the off-normal mode the inlet of unit 5 is connected to the outlet of unit 3 by unit 4 so the organic iodine content of the air is also monitored. See Figure 2 in chapter [3.2.2](#).

This sequence remains valid until warning signals cease for both detectors at the same measurement. Contaminated filters cannot be used again after the regular cooling period. Background measurements are omitted in off-normal mode.

## 4.8 Measurement of selected samples in the measuring position (“Extra” mode)

Different samples (e.g. a prepared calibration source) can be measured on each measuring position, depending on the regular function of the measuring position, but without the use of the pump.

Upon initiating this mode by the appropriate interactive command the pump is stopped immediately and the selected filter with the selected sample is taken.

# 5 DATA EVALUATION PROCEDURES

1. Gain check
2. Background measurements
3. Continuous sampling in normal and off-normal operation
4. High resolution gamma spectrometry

## 5.1 Gain test

### 5.1.1 Gain test of units #2 and #3

Version 1: aerosol gamma NaI(Tl) detector (chapter 3.1.2) and Iodine NaI(Tl) detector (chapter 3.1.4).

The structural position of units #2 and #3 is shown on Figure 1 in Chapter 2. The pulse height versus energy calibration of the NaI(Tl) scintillation detectors facing the aerosol and the iodine filters are checked by measuring a <sup>137</sup>Cs test source (“Source #2”). The channels of the MCA are separated into several regions (8 for NaI(Tl) detectors). The proper gain setting of a NaI(Tl) detector can be indicated by the ratios of the net counts in the neighbouring regions to the net counts in the region of the peak of the test source:

$$\frac{YM[j] - YB[j]}{YM[p] - YB[p]} \leq FG_{13}[j] \quad \text{where } j = p - 1 \text{ or } p + 1 \quad [1]$$

p denotes the peak region, YM denotes the measured counts of the test source, YB denotes the background counts, FG<sub>13</sub> is the gain check factor. The resulting message is "OK." or "FAILED". The measurement lasts at most for 3x300 seconds (for background and sample, respectively). The first

measurement of 300 s duration is extended two more times to a consecutive 300 second cycle if the test fails. As the calibrating sources are very weak (that is, they are well below the radioactivity

exemption level), nuclear statistics are rather poor, so the peak analysis program may sometimes overlook a “deviant” full energy peak.

### 5.1.2 Gain test of unit #2

#### Version 2: aerosol gamma HPGE detector (Chapter 3.1.3)

The  $^{137}\text{Cs} - ^{133}\text{Ba} - ^{60}\text{Co}$  test source (“Source #1”) is applied for the HPGE semiconductor detector. The gamma spectrum is taken for (3x) 300 seconds. The peak centre PCM (recognised by the gamma-spectrometric data processing subroutine of the program described in Chapter 5.4) is compared to its expected value PCC given by the installing calibration procedure:

$$|PCM - PCC| \leq FG_2 \quad [3]$$

FG2 is the largest tolerable deviation from the presumed peak centre PCC.

## 5.2 Background measurements

The continuous sampling and evaluation cycle based on the aerosol and iodine filters starts with a fifteen-minute background measurement. As long as no excess (either natural or non-natural) radioactivity is observed on either of the filters, the measured data are attained to the external background and added to the aggregate background variables. This “iterative” procedure is optional, as it can be misleading in some special cases, e.g. in case of the significant fluctuation of the external photon radiation background.

$$BG[i] = \frac{SBG[i]}{BN} \quad i = 1, \dots, 8/6 \quad [4]$$

$$SBG[i] = \sum_{j=1}^{BN} YB[i, j] \quad [5]$$

$$VBG[i] = \frac{\sum_{j=1}^{BN} (YB[i, j] - BG[i])^2}{BN * (BN - 1)} \quad [6]$$

The parameter *i* denotes the discrimination regions (8 for NaI(Tl), 6 for PIPS) BN is the number of measurements deemed as exempt from any radioactivity on the filter (see Chapter 5.3.1 for this evaluation), BG’s are the average background counts, SBG’s are the sums of the appropriate background counts, VBG’s are the variances of the BG’s. Obviously, the array of background counts is determined separately for the respective measuring positions.

### 5.3 Continuous sampling in normal and off-normal operational modes

Two kinds of situations may occur during the sampling cycle:

- The sum of the observed counts does not differ significantly from the total background: the usual case with the iodine filter; and
- The sum of the observed counts is significantly higher than the total external background: the usual case with the aerosol filter.

$$SN = \sum_{i=1}^8 YM [i] - \sum_{i=1}^8 BG [i] \quad [7]$$

$$VSN = \sum_{i=1}^8 YM [i] + \sum_{i=1}^8 VBG [i] \quad [8]$$

$$SN \geq 2 * \sqrt{VSN} \quad [9]$$

SN is the sum of the net counts (i.e., that of the zone-by-zone difference between the measured counts YM and the background BG), VSN is its variance. If criterion [9] is met, calculations are continued with the assumption of an underlying natural radon environment (Subroutine TEST for artificial nuclides). If this condition is not met, the sample is considered exempt from adsorbed radioactivity and the counts can be used to iterate the aggregate background array.

#### 5.3.1 Subroutine "TEST for artificial nuclides"

##### 5.3.1.1 Evaluation of scintillation gamma counts

The relative differential distribution of the counts is calculated for the energy regions:

$$ND[i] = YM [i] - BQ[i] \quad i = 1, \dots, R \quad [10]$$

$$RMQ[i] = ND[i] / SN \quad i = 1, \dots, R \quad [11]$$

$$RNQ[i] = \sqrt{(YM[i] + SBG[i]^2) / ND[i] + VSN / SN^2} \quad i = 1, \dots, R \quad [12]$$

ND [i] 's are the net differential counts, NQ's are the net ratios, RNQ's are the associated relative standard deviations. R is the number of energy regions. The calibrated relative differential spectrum of radon daughters CQ [i] is compared to the measured ratios (quotients) by defining a quality factor QF [i]:

$$QF[i] = NQ[i] / CQ[i] \quad i = 1, \dots, R \quad [13]$$

$$RQF[i] = \sqrt{RNQ[i]^2 + RCQ[i]^2} \quad i = 1, \dots, R \quad [14]$$

RQF [i] is the relative standard deviation of the quality factor, RCQ [i] is the experimental standard deviation of the calibrated quotient CQ in the i-th zone. Obviously, the expected value of QF is 1 if there is no source of artificial radioactivity on the filter. It is worth noting that the relative spectral distribution of the actual composition of the radon descendants depends on the equilibrium between

the consecutive descendants as well as on the presence or absence of significant concentration of <sup>220</sup>Rn-series, so the CQ-values depend on the actual <sup>220</sup>Rn/<sup>222</sup>Rn-ratio.

$$\frac{QF[i]-1}{RQF[i]} = Q[i] \quad [15]$$

$$Q[i] > SF \quad [16]$$

Q[i] is the resulting quality parameter for the i-th zone; it compares the difference between the actual and the expected values of the quality factor to its estimated standard deviation. SF is a semi-empirical significance factor with a value of 3 or 2x(RQF[i] + 1), whichever is smaller. If criterion [16] is met, the high value of Q[i] indicates the presence of a non-natural radionuclide. The serial number of the zone with the largest Q[i] value can lead to a rough assumption for the identity of the nuclide(s). [Table III.1.](#) shows the most probable radionuclides forming the contamination.

| Zone no. | Main gamma energy (keV) | Displayed message | Radionuclides  |
|----------|-------------------------|-------------------|--|
| 1        | Bremsstrahlung          | BETA              | e.g. <sup>90</sup> Sr/ <sup>90</sup> Y                         |
| 2        | 81 - 250                | NOBLE GAS         | <sup>133</sup> Xe, <sup>133m</sup> Xe, <sup>135</sup> Xe, etc. |
| 3        | 365                     | I-131             | <sup>131</sup> I   |
| 4        | 530                     | I-133             | <sup>133</sup> I   |
| 5        | 662                     | Cs-137            | <sup>137</sup> Cs  |
| 6        | 700 - 1100              | MIXED             | e.g. <sup>134</sup> Cs, <sup>110m</sup> Ag                     |
| 7        | 1100 - 1500             | MIXED             | e.g. <sup>60</sup> Co, <sup>59</sup> Fe                        |
| 8        | 1500 - 1800             | MIXED             | e.g. <sup>42</sup> K, <sup>24</sup> Na                         |

**Table III.1.**  
**Assumptions for potential contaminating radionuclides**

The deviation of the quality factors from their expected value of 1 indicates that a radioactive component other than the radon daughters is present on the filter. If the significance criteria for the quality parameters are met for neither of the zones, the exclusive presence of radon descendants is confirmed. The reproducible pumping rate enables the approximate assessment of radon concentration in the sampled atmosphere.

Would a significant zone count occur, not only a warning message is generated but the radioactivity present on the filter is also assessed using a rough estimation of the counting efficiency:

$$AC = (YM[im] - BG[im]) / t_m * (1/EFF[im]) \quad [17]$$

'im' is the number of the zone with the largest and/or most significant quality parameter Q[i], tm is the measuring time, the mean counting efficiencies EFF [i]'s belonging to each zone are calibrated. In case of normal operation only the marginal values of the atmospheric activity concentration can be calculated. Two assumptions are applied:

- The minimum airborne concentration ACCN is determined by using the total volume of air processed so far, that is, the maximum volume VOLX;

- The maximum airborne concentration ACCX is determined by using the volume of air pumped through the filter during the last measurement period, that is, the minimum volume VOLN.

$$ACCN = AC/VOLX \quad [18]$$

$$ACCX = AC/VOLN \quad [19]$$

In case of off-normal operation, the volume of the air (VOL) that may contain the adsorbed contaminant is considered as the processed volume since the last change of filter so the activity concentration ACC can be given more accurately:

$$ACC = AC/VOL \quad [20]$$

### 5.3.1.2 Evaluation of alpha/beta-counting

The formulation of the evaluation of the alpha/beta-spectrum is quite similar to the procedure described above. There are 6 energy regions (zones) in this case. The physical data of the most important natural alpha emitters are given in Table III.2. below:

| Nuclide           | Series            | Alpha energy<br>(MeV) | Energy region<br>(zone) |
|-------------------|-------------------|-----------------------|-------------------------|
| $^{218}\text{Po}$ | $^{222}\text{Rn}$ | 6.00                  | 3.                      |
| $^{214}\text{Po}$ | $^{222}\text{Rn}$ | 7.69                  | 5.                      |
| $^{216}\text{Po}$ | $^{220}\text{Rn}$ | 6.78                  | 4.                      |
| $^{212}\text{Bi}$ | $^{220}\text{Rn}$ | 6.07                  | 3.                      |
| $^{212}\text{Po}$ | $^{220}\text{Rn}$ | 8.78                  | 6.                      |

**Table III.2.**  
**Alpha emitting radon descendants**

The most probable artificial alpha emitting radionuclides are  $^{238}\text{Pu}$ ,  $^{239}\text{Pu}$  and  $^{240}\text{Pu}$ ,  $^{241}\text{Am}$ . Their peaks fall in region 2. (between 4.0 and 5.7 MeV). Region 1 contains all the beta pulses. (< 3 MeV). Net counts are calculated according to the equations below. Calibrated contribution (cross-talk) of peaks in upper regions to the counts in lower regions is subtracted in addition to the background.

$$ND[i] = YM[i] - BQ[i] \quad (i = 1, 2, \dots 6) \quad [21]$$

$$N[6] = ND[6] \quad [22]$$

$$N[5] = ND[5] - CT_{65} \times N[6] \quad [23]$$

$$N[4] = ND[4] - CT_{64} \times N[6] - CT_{54} \times N[5] \quad [24]$$

Notation: N: net alpha counts; CT: "cross talk" coefficient

Peak areas of radon descendant components are given in Table III.2. are calculated "backwards", starting with the undisturbed  $^{212}\text{Po}$  peak from the high energy side.

$$NT[3] = N[6] \times EQ_{63} \quad [25]$$

$$NR[3] = ND[3] - ( NT[3] + CT_{63} \times N[6] + CT_{53} \times N[5] + CT_{43} \times N[4] ) \quad [26]$$

$$N[3] = NT[3] + NR[3] \quad [27]$$

EQ is a time-dependant equilibrium coefficient. The alpha counts of the possible artificial nuclides are determined as the significant positive content of region 2 that remains after subtracting all the cross-talk pulses.

$$N[2] = ND[2] - \sum CT_{j2} \times N[j] \quad (j = 3 \dots 6) \quad [28]$$

$$N[2] \geq SF \times \sqrt{\text{Var}(N[2])} \quad [29]$$

The default value of the significance coefficient SF is 3 (given in the INI file). The possible significant counts of artificial beta emitters are determined in a similar way from the gross counts in region 1:

$$N[1] = ND[1] - \sum CT_{j1} \times N[j] - CT_{21} \times N[2] - N[6] \times EQ_{61} \times EC_{61} - N[5] \times EQ_{51} \times EC_{51} \quad (j = 3, \dots 6) \quad [30]$$

EC is the efficiency ratio between beta and alpha counting. The parameters SF, CT, EQ and EC must be pre-calibrated. If the values of N[1] and/or N[2] are significant, the activity concentrations are calculated by the likes of equations [17] - [20]. Depending on their amount, "warning" or "alarm" signals are generated.

## 5.3.2 Subroutine "RADON"

### 5.3.2.1 Evaluation of gamma counting

The discrimination zones of the NaI(Tl) detector listed in [Table III.1](#), can be divided into two parts in terms of the radon descendant spectrum: zones 1 - 3 contain the full energy peaks of <sup>214</sup>Pb, Compton contribution from the peaks of <sup>214</sup>Bi and the associated backscatter peaks; zones 4 - 8 contain contribution only from <sup>214</sup>Bi (see [Table III.3](#).) Therefore, an aggregate correction factor was determined for subtracting the contribution of <sup>214</sup>Bi from the summed net counts of zones 1 - 3 considering the energy vs. efficiency and energy vs. peak-to-Compton-ratio functions of the two similar NaI(Tl) detectors. The aggregate efficiency factors applicable to zones 4 - 8 for <sup>214</sup>Bi and zones 1 - 3 for <sup>214</sup>Pb were calibrated.

$$CT_{Pb} = \sum_{i=1}^3 ND[i] \quad [31]$$

$$CT_{Bi} = \sum_{i=4}^8 ND[i] = NCT_{Bi} \quad [32]$$

CT's are the sums of the counts in the appropriate zones.

| Radon descendants | Half-life (min) | Main photon energies (keV) | Abundance rel. to 1000 decays |       |     |
|-------------------|-----------------|----------------------------|-------------------------------|-------|-----|
| <sup>218</sup> Po | 3.05            | -                          | -                             |       |     |
| <sup>214</sup> Pb | 26.8            | 53.2                       | 11                            |       |     |
|                   |                 | 74.8 + 77.1                | 176                           |       |     |
|                   |                 | 87.2 + 90.1                | 50                            |       |     |
|                   |                 | 241.9                      | 75                            |       |     |
|                   |                 | 295.2                      | 192                           |       |     |
|                   |                 | 351.9                      | 371                           |       |     |
|                   |                 | <sup>214</sup> Bi          | 19.7                          | 609.3 | 461 |
|                   |                 |                            |                               | 768.4 | 49  |
| 934.6             | 32              |                            |                               |       |     |
| 1120.3            | 150             |                            |                               |       |     |
| 1238.1            | 59              |                            |                               |       |     |
| <sup>214</sup> Po | 2.7e-6          | 1377.7                     | 40                            |       |     |
|                   |                 | 1764.5                     | 159                           |       |     |
|                   |                 | -                          | -                             |       |     |
|                   |                 | -                          | -                             |       |     |

**Table III.3.**  
**Decay parameters of short-lived radon-222 descendants**

$$NCT_{Pb} = CT_{Pb} - FC_{45} * (ND[4] + ND[5]) - FC_6 * ND[6] - FC_{78} * (ND[7] + ND[8]) \quad [33]$$

NCT is the total of net counts attributed to the gamma emitting radon daughter, FC's are the calibrated correction factors for the discrimination zones. They were determined with a spectrum generating computer program and then modified according to the experimental results. The activity of radon descendants in air can be described adequately with a set of differential equations:

$$A_{218Po} = \frac{dN_{Po}}{dt} = \frac{C_{Po} * VR}{\lambda_{Po}} - \lambda_{Po} * N_{Po} \quad [34]$$

$$A_{214Pb} = \frac{dN_{Pb}}{dt} = \frac{C_{Pb} * VR}{\lambda_{Pb}} - \lambda_{Pb} * N_{Pb} + f_{Po/Pb} * \lambda_{Po} * N_{Po} \quad [35]$$

$$A_{214Bi} = \frac{dN_{Bi}}{dt} = \frac{C_{Bi} * VR}{\lambda_{Bi}} - \lambda_{Bi} * N_{Bi} + f_{Pb/Bi} * \lambda_{Pb} * N_{Pb} \quad [36]$$

dt means differentiating according to the elapsed time, the A's are the activities adsorbed onto the filter, the N's are the number of the respective nuclides, the C's are the activity concentrations (in Bq/m<sup>3</sup>) of the respective nuclides in the atmosphere, λ's are the decay constants (in min<sup>-1</sup>). VR is the actual volume rate of the air pump (in m<sup>3</sup>/min), f<sub>Po/Pb</sub> and f<sub>Pb/Bi</sub> are the equilibrium factors of the consecutive radon progenies. According to literature references (e.g. "Measurement of radon and radon daughters in air" NCRP Report #97, 1988, U.S. NCRP) these factors differ significantly from 1, that is, from the proper state of equilibrium even for outdoor air. Widely accepted recommendations for the values are

$$C_{Rn-222} : C_{Po-218} : C_{Pb-214} : C_{Bi-214} = 1 : 0.9 : 0.7 : 0.6$$

for the "bulk" outdoor atmosphere. However, these ratios of outdoor radon descendant concentrations cannot be used for describing the equilibrium factors which are valid for the solid layers sorbed onto

the filter. As a rough approximation, the difference from the ideal state of equilibrium is taken as half of that of the recommended bulk outdoor mean:

$$\begin{aligned} f_{\text{bulk,Rn/Po}} &= fb_1 = 0.9 \\ f_{\text{bulk,Po/Pb}} &= fb_2 = 0.7/0.9 = 0.78 \\ f_{\text{bulk,Pb/Bi}} &= fb_3 = 0.6/0.7 = 0.85 \\ f_{\text{filter,Rn/Po}} &= ff_1 = 0.95 \\ f_{\text{filter,Po/Pb}} &= ff_2 = 0.89 \\ f_{\text{filter,Pb/Bi}} &= ff_3 = 0.92 \end{aligned}$$

The arresting efficiency of the aerosol filter proved better than 98.5 % so no correction was required for it.

Substituting the respective bulk and filter equilibrium factors to equations [34] - [36] they can be solved for  $N_{Po}$ ,  $N_{Pb}$  and  $N_{Bi}$ , giving the number of the radon daughter nuclei present on the filter as a function of pumping time. The respective activities are simply generated by multiplying the equations with the respective decay constants  $\lambda_{Po}$ ,  $\lambda_{Pb}$  and  $\lambda_{Bi}$

$$A_{214_{Pb}} = A_2 = VR * C_{Rn} * fb_1 \left\{ \left( \frac{fb_2}{\lambda_2} + \frac{ff_2}{\lambda_1} \right) * (1 - e^{-\lambda_2 t}) + \frac{ff_2 * \lambda_2}{\lambda_1 * (\lambda_2 - \lambda_1)} * (e^{-\lambda_2 t} - e^{-\lambda_1 t}) \right\} \quad [37]$$

$$A_{214_{Pb}} = A_2 = VR * C_{Rn} * fb_1 \left\{ \left( \frac{fb_2 * fb_3}{\lambda_3} + \frac{fb_2 * ff_3}{\lambda_2} + \frac{ff_2 * ff_3}{\lambda_1} \right) * (1 - e^{-\lambda_3 t}) + \left( \frac{fb_2 * ff_3 * \lambda_3}{\lambda_2 * (\lambda_3 - \lambda_2)} + \frac{ff_2 * ff_3 * \lambda_3}{\lambda_1 * (\lambda_3 - \lambda_2)} - \frac{ff_2 * ff_3 * \lambda_2 * \lambda_3}{\lambda_1 * (\lambda_2 - \lambda_1) * (\lambda_3 - \lambda_2)} \right) * (e^{-\lambda_3 t} - e^{-\lambda_2 t}) + \frac{ff_2 * ff_3 * \lambda_2 * \lambda_3}{\lambda_1 * (\lambda_2 - \lambda_1) * (\lambda_3 - \lambda_1)} * (e^{-\lambda_3 t} - e^{-\lambda_1 t}) \right\} \quad [38]$$

For the sake of brevity, the indices were changed: "1" denotes  $^{218}Po$  (the first daughter product), "2" denotes  $^{214}Pb$  and "3" denotes  $^{214}Bi$ . The expressions within the primary parentheses of equations [37] and [38] can be referred to as  $tf_2$  and  $tf_3$  (time dependent factors), respectively.

The activities of  $^{214}Pb$  and  $^{214}Bi$  can be expressed from the measured net counts as well:

$$A_{214_{Pb}} = A_2 = \frac{NCT_{Pb}}{t_m * EFF_{Pb}} \quad [39]$$

$$A_{214_{Bi}} = A_3 = \frac{NCT_{Bi}}{t_m * EFF_{Bi}} \quad [40]$$

$t_m$  is the measuring time, the EFF's are the experimental efficiencies combining the total counting efficiencies, peak-to-total ratios and gamma-abundance of the considered major gamma lines (See [5.4.5](#) for details).

Two separate solutions can be obtained for  $C_{Rn}$ , the estimated radon equilibrium concentration in the atmosphere, if the appropriate equations [37] and [39], [38] and [40] are combined:

$$C_{Rn}(2) = \frac{NCT_{Pb}}{t_m * EFF_{Pb}} * \frac{1}{VR * fb_1 * tf_2} \quad [41]$$

$$C_{Rn}(3) = \frac{NCT_{Bi}}{t_m * EFF_{Bi}} * \frac{1}{VR * fb_1 * tf_3} \quad [42]$$

The arithmetic mean of the two values is displayed by the program as an estimated radon equivalent equilibrium concentration EEC in units  $Bq/m^3$ .

### 5.3.2.2 Evaluation of alpha/beta-counting

The count rates of the alpha emitting radon descendants are calculated by equations [21]-[28] in Section 5.3.1.2. The activity concentration is given below:

$$C_{218Po} = NR[3]/(t_m \cdot EFF_3) \quad [43]$$

$$C_{214Po} = N[5]/(t_m \cdot EFF_5) \quad [44]$$

Equivalent equilibrium concentration is in turn given:

$$EEC = 0.105 \times C_{218Po} + 1.041 \times C_{214Po} \quad [45]$$

This equation differs from the original one introduced e.g. in the already cited reference book "Measurement of radon and radon daughters in air" NCRP Report #97, 1988, U.S. NCRP", as the contribution of the non-alpha emitting  $^{214}Pb$  is substituted by a modified term containing  $C_{214Po}$  only, which is in turn strictly equal to  $C_{214Bi}$ , due to its extremely short half-life.

The PIPS spectrum is suitable for the accurate determination of  $^{220}Rn$  EEC as well if the thoron activity on the aerosol surface becomes significant. The equations are similar to [43] and [45] given above, but the evaluation is based exclusively on N[6], the net counts of region #6 of the PIPS spectrum.

## 5.4 Gamma spectrometry

Gamma spectra taken by the HP Ge detector are treated in a special way. Full energy peaks are selected and identified. Spectrum evaluation includes the following steps:

- Peak search
- Peak area calculation
- Peak fitting
- Identification
- Activity calculation

### 5.4.1 Peak search

Full-energy peaks are recognised on the basis of the significance of the smoothed second numerical derivatives of the spectra applying a 7-point convolution. Data of the expected peak width (full-width-at-half-maximum, FWHM) calibration are required for the analysis. Peak centres are listed, suspected

overlaps are labelled. Energy vs. channel number calibration is used for determining and displaying the energies of the recognised gamma lines.

### 5.4.2 Peak area calculation

Peak regions are designated by examining the slopes (first derivatives) of both sides of the peak centres. A common peak region is assigned to overlapping peaks. Areas are first estimated with the simple trapezoid method:

$$AR = \sum_{i=X_L}^{X_R} Y[i] - \frac{YS[X_R] + YS[X_L]}{2} * (X_R - X_L + 1) \quad [46]$$

$$SDAR = \sqrt{AR + (YS[X_R] + YS[X_L]) * \left[ \left( \frac{X_R - X_L + 1}{2} \right)^2 + \frac{X_R - X_L + 1}{2} \right]} \quad [47]$$

AR is the area of the singlet or multiplet, SDAR is its standard deviation (both are given in counts), XL and XR are the left and right boundary channels, resp., Y's are the channel contents, YS's are the smoothed channel contents obtained with a 5-point smoothing routine. A significance criterion of SDAR/ AR < 0.5 is tested for excluding spurious peaks.

### 5.4.3 Peak fitting

The peak shape of the HP Ge detector response is approximated and fitted with an asymmetric multi-parameter function:

$$y_j(i) = AMP_j \cdot \exp \left( - (i - c_j)^2 / (2 \sigma_j^2) \right) \quad [i \geq c_j - p_j^2] \quad [48]$$

$$y_j(i) = AMP_j \cdot \exp \left( - (2i - 2c_j + p_j^2) / (2 \sigma_j^2) \right) \quad [i < c_j - p_j^2] \quad [49]$$

$$y(i) = \sum y_j(i) + b_1 + b_2 \cdot i \quad [50]$$

AMP is the peak height (amplitude), c is the peak centre,  $\sigma$  is the peak width parameter. i denotes the channel number, j denotes the serial number of a peak in an overlapping peak region.  $p_j$  is the j-th asymmetry parameter, the square indicates that it is forced to be positive in the iterative least squares routine used in the calibration procedure. b's are the background parameters, an optional quadratic background can also be specified.

The asymmetric "low energy tailing" component (eq. [49]) joins smoothly to the central Gaussian, their width parameter is common and the ordinates and the first derivatives of the components are identical at the junction point. In routine analysis the least-squares regression is linearised, the non-linear parameters are fixed and kept constant for the fitting procedure. Peak centres are taken from a preceding peak search routine which is based on a numerical convolution of the channel contents with the second derivative of an appropriate Gaussian. Peak widths and the positions of the junction point of the asymmetric component (relative to the peak centre) are taken from previously determined calibration files.

The acceptance criterion for a full energy peak is the significance of the amplitude:

$$\frac{SDAMP [j]}{AMP [j]} \leq 0.8 \quad [51]$$

Insignificant peaks are deleted from the peak list, and the area calculation and peak fitting steps are repeated from the assignment of (possibly) new peak boundaries. Peak areas (AR) and standard deviations (SDAR) are generated from the calculated ordinate values of the fitted peak shape function within the respective peak limits, thus substituting the results of equation [45] and [46].

Insignificant peaks are deleted from the peak list, and the area calculation and peak fitting steps are repeated from the assignment of (possibly) new peak boundaries. As soon as no further deletion is required, areas of the fitted Gaussians are calculated. In case of singlets, the "realistic" and the "Gaussian" areas are compared:

$$AR[k] \geq 1.064 * AMP[k] * FWHM[k] \quad [52]$$

k denotes the serial number of the peak in the peak list. The larger value is used for calculating the peak intensity IP[k] by dividing the area with the measurement time. A similar selection is done for multiplets:

$$MAR = \max \left\{ AR[m], \sum_{j=1}^{NP} 1.064 * AMP[j] * FWHM[j] \right\} \quad [53]$$

MAR is the maximum of the sum of the fitted areas and the estimated common area of the region. It is assumed that the m-th multiple contains NP peaks. In turn, the individual areas are apportioned according to their heights and peak widths.

$$IP[r + j - 1] = \frac{1}{t_m} * \frac{AMP[j] * FWHM[j]}{\sum_{k=1}^{NP} AMP[k] * FWHM[k]} * MAR \quad j = 1, \dots, NP \quad [54]$$

r denotes the respective serial number of the first peak of the multiplet in the final peak list.

#### 5.4.4 Identification of observed full-energy peaks

Two techniques/algorithms are provided for the identification of radioisotopes: a traditional method of peak-by-peak analysis and a so-called matrix identification procedure.

##### 5.4.4.1 Peak-by-peak analysis

An isotope library is provided that contains the following elements: code number, isotope name, value and unit of half-life, gamma energies in keV, the associated gamma abundance (per one decay) and an indication of the main gamma line of the isotope in question. Its items are compared to the data of the peaks. Decisions are to be made whether the following conditions are met:

- energy match between a gamma line in the data library and a peak in the spectrum
- if a line other than the matching one is marked as "main line" for the given isotope, the presence of the main line in the spectrum is checked and the intensity ratio of the respective peaks is compared to the ratio of the respective efficiency-corrected gamma abundance.

##### 5.4.4.2 Matrix identification

This routine is optional in the gamma-spectrometric analysis program of the control centre of the monitoring network. A least-squares model is established according to eq. [51]:

$$R = \sum_{i=1}^N (I_i - \sum_{j=1}^M (A_j \cdot f_j \cdot \epsilon_i))^2 \cdot w_i \quad [55]$$

I<sub>i</sub> is the intensity (in cps) of the i-th peak region of the spectrum, A<sub>j</sub> is the activity (in Bq) of the j-th isotope selected according to the energy match condition, f<sub>j</sub> denotes the gamma-abundance of the matching gamma-line, ε<sub>i</sub> is the efficiency valid for the region in question, w is the statistical weight of

the i-th component of the least-squares sum (the reciprocal of the variance of the intensity). N is the number of the separate peak regions in the spectrum (i=1,2,... N), and M is the number of the "suspected" isotopes (j=1,2,...M). Differentiating R for Aj's results in a set of linear homogeneous equations which can be readily solved for Aj's if N is larger than M.

In spite of the apparent advantage that this procedure provides accurate results even for irresolvable overlapping peaks, in some cases matrix identification will lead to an underdetermined situation with no realistic outcome. This case occurs when two gamma lines without any other associated peak fall into the same peak region.

#### 5.4.5 Activity calculations

Data from the energy vs. full-energy peak efficiency calibration and gamma abundance from the isotope library are necessary for determining the activity of the identified radionuclides:

$$ACT[i] = \frac{IP[i]}{EFF[i]*GM[i]} \quad [56]$$

EFF [ i ] is the efficiency for the i-th item in the peak list, GM [ i ] is its gamma abundance. If the sample was taken in off-normal mode, the activity concentrations in the atmosphere can also be assessed.

$$ACC[i] = \frac{ACT[i]}{VOL} \quad [57]$$

ACC is the activity concentration in Bq/m3, VOL is the volume of air pumped through the filter. Results are listed on the display. All the results of the evaluation routines are stored in files as well for further inspection and transmission.

## 6 SENSITIVITY

The smallest detectable radioactivity is calculated and determined for all detectors of the system, considering only realistic sampling and measurement situations. The figures are given in [Table IV. 1.](#) below are in Bq/m<sup>3</sup> units. They relate to the detector types, source-to detector geometry and - last but not least - to the data processing subroutines applied in the AMS-02 system only. These values change from measurement to measurement, depending primarily on the actual radon concentration.

| Isotop filter/Detector                         | Limit of detection (LD) [Bq/m <sup>3</sup> ] |        |          |
|--|--|--------|----------|
|  | duration of air filtering                    |        |          |
|  | 5 min  | 1 hour | 24 hours |
| <b>Normal Mode</b>                             |  |        |          |
| <sup>131</sup> I aerosol/Nal(Tl)               | 5.4  | 0.8    | 0.066    |
| <sup>131</sup> I iodine/Nal(Tl)                | 6.4  | 0.2    | 0.044    |
| <sup>137</sup> Cs aerosol/Nal(Tl)              | 4.1  | 0.5    | 0.056    |
| α-Activity ( <sup>239</sup> Pu) aerosol/PIPS   | 1.5  | 0.2    | 0.022    |
| β-Activity ( <sup>90</sup> Sr) aerosol/PIPS    | 2.5  | 0.3    | 0.052    |
| <sup>137</sup> Cs aerosol/HPGe                 | 6.7  | 0.77   | 0.006    |
| <b>Off-Normal-Mode (organic iodine filter)</b> |  |        |          |
| <sup>131</sup> I iodine/Nal(Tl)                | 8.7  | 0.52   | 0.058    |

**Table IV. 1.**  
**Sensitivities (limits of detection) of the AMS 01 system**  
**(Bq/m<sup>3</sup>)**

Data pertain to an assumed elevated natural radon background of 20 Bq/m<sup>3</sup> EEC.  
Air flow rate is 8 m<sup>3</sup>/h.

## 7 APPENDIX

### 7.1 The AMS-02 CONTROL Software

Important parts of the AMS-02 CONTROL Software

- **AMSCTRL.EXE**  
The main program of the AMS-02 CONTROL Software. It operates the manipulator system, performs and evaluates the measurements, stores the results and sets connection to the regulatory centre.
- **AMSCONTROL.EXE**  
the control program of the manipulator system. This program executes commands from AMSCTRL.EXE.
- **GSMATH.EXE**  
the gamma spectrum analysis program of the AMS-02 CONTROL Software. It analyzes HPGe spectra so it is active only on the station which is equipped with such detector.
- **GSMATHLD.EXE**  
the ancillary program of GSMATH.EXE. This program calculates detection limits (LD's) for gamma lines of different isotopes selected by the nnTH\_\_\_\_.i00 INI file.
- **FILTER.DBF**  
dBase-type file containing all data of filters.
- **AMS02VIEW.EXE**  
utility program of the AMS-02 CONTROL software. This program shows direct measurement data and results of evaluation.

### 7.2 Communications Software

- **AutoFTP**  
Programmable FTP client program for communication. This program transferred the data to the data central.

## 8 DETAILED DESCRIPTION OF MAINTENANCE

### 8.1 MAINTENANCE

The maintenance of the equipment serves to prevent possible failures of the instruments to ensure permanent operative reliability of the equipment by a regular control of the measured values, visual inspection and preventive exchange.

#### 8.1.1 MAINTENANCE checklist for AMS02

| Description   | Quarterly | half-yearly | yearly | Installation | action                                     |
|---|-----------|-------------|--------|--------------|--|
| <b>AMS02 Hardware</b>   |           |             |        |              |  |
| Visual inspection of the whole system   | X         | X           | X      | X            |  |
| mechanical and visual inspection of the stepping motor, toothed belt, gearwheel                     | X         | X           | X      | X            | Replace failing components                 |
| Single function test of the mechanical and electronic parts   | X         | X           | X      | X            | Replace failing components                 |
| Cleaning of dust which could effect the instrument operate reliability                              | X         | X           | X      |              |  |
| Adjustment of the mechanical moving parts of the instrument   | X         | X           | X      | X            |  |
| Check of the supply voltages of the whole Instrument  |           |             | X      | X            |  |
| Check and adjustment of all the complete manipulator system (clean and oil with sewing machine oil) | X         | X           | X      | X            |  |
| Energy Calibration of all detectors   | X         | X           | X      | X            | above 3% deviation adjust by HW else by SW |
| Efficient Calibration of all detectors  |           |             | X      | X            | spectrum evaluation over Online support    |
| Exchange of filters „Hole“, „Dusted“, „Worn“ and „Contaminated“                                     |           |             | X      |              |  |
| Evaluation of filters „Hole“, „Dusted“, „Worn“ and „Contaminated“                                   | X         | X           | X      |              | (also incl. in online maintenance)         |
| Exchange of charcoal filter for organic iodine  |           |             | X      |              |  |
| Exchange the Mylar Clingfilm cover of PIPS detector   |           |             | X      |              |  |
| Inspection of the gasket of the filter chamber  | X         | X           | X      | X            |  |
| Check the carbon sheet of air pump  |           |             | X      |              | Exchange it if necessary. (<22mm)          |
| Check the fixing mechanical system in the measuring positions                                       | X         | X           | X      | X            |  |
| Check the density of the vacuum   |           |             | X      | X            |  |
| Check the ball valve of Organic Iodine measure chamber (check moving)                               |           | X           | X      | X            |  |
| Check of the pressure sensors   |           | X           | X      | X            |  |

BITT Technology  
Manual AMS02

| Description   | Quarterly | half-yearly | yearly | Installation | action                              |
|---|-----------|-------------|--------|--------------|-------------------------------------|
| Check of the air flow rate, and if necessary correction of the air flow rate constants                |           | X           | X      | X            |                                     |
| Inspection of the filter position in the rack   |           |             | X      | X            | Position error (SW) or mech. repair |
| Check the filter position 601 and 602   | X         | X           | X      | X            | Position error (SW) or mech. repair |
| Check the position of the calibration filters in the magazine   | X         | X           | X      | X            |                                     |
| Clean or exchange air filter  |           | X           | X      |              |                                     |
| Check the system fans   | X         | X           | X      | X            | Replace after max. 2 years          |
| <b>AMS02 Software</b>   |           |             |        |              |                                     |
| Windows upgrade   | X         | X           | X      |              | if available                        |
| Virus scan upgrade  | X         | X           | X      |              | if available                        |
| Virus Database update   | X         | X           | X      | X            | if available                        |
| Micro controller Programs upgrade   | X         | X           | X      | X            | if available                        |
| Ams02Contol (MANIP) upgrade   | X         | X           | X      | X            | if available                        |
| AmsCtrl upgrade   | X         | X           | X      | X            | if available                        |
| Archive Log-Files   |           | X           | X      |              |                                     |
| Check Disk, Defrag disk   |           |             | X      |              |                                     |
| Backup  |           | X           | X      | X            |                                     |
| Check Program-Parameter   | X         | X           | X      | X            |                                     |
| <b>Final Test</b>   |           |             |        |              |                                     |
| System Start warm and cold start  | X         | X           | X      | X            |                                     |
| Background-control for the detectors  | X         | X           | X      | X            |                                     |
| Gaintest-check  | X         | X           | X      | X            |                                     |
| Adjust Gain   | ?         | ?           | ?      | ?            | if necessary                        |
| <b>Air conditioner</b>  |           |             |        |              |                                     |
| Check and set up the temperature  | X         | X           | X      | X            |                                     |
| Air-condition check   | X         | X           | X      | X            |                                     |
| Cleaning or exchanging of the air conditioner filter  |           | X           | X      |              | (by a local company)                |
| Complete cleaning of the air conditioner twice a year to prevent damages due to possible overheating. |           | X           | X      |              | (by a local company)                |
| <b>UPS</b>  |           |             |        |              |                                     |
| Check of the switch from mains- to battery operation  | X         | X           | X      | X            |                                     |
| Check of the accumulators charging state, both charging and discharging status.                       | X         | X           | X      | X            |                                     |
| <b>RS03 gamma meter</b>   |           |             |        |              |                                     |
| Check of wire between the probe and the data collector unit   |           | X           | X      | X            |                                     |
| Check of supply voltage and current drain at the probe  | X         | X           | X      | X            |                                     |
| Control of the status messages of the probe (serial interface).                                       | X         | X           | X      | X            |                                     |
| Check the background  | X         | X           | X      | X            |                                     |
| <b>Meteorological components</b>  |           |             |        |              |                                     |
| Visual inspection of the measuring modules mounted at the mast  | X         | X           | X      | X            |                                     |

BITT Technology  
Manual AMS02

|   |           |             |        |              |  |
|---|-----------|-------------|--------|--------------|--|
| Single functional check of the mechanical and electronic parts                      | X         | X           | X      | X            |  |
| Cleaning of dust of rain quantity sensor  | X         | X           | X      | X            |  |
| Description   | Quarterly | half-yearly | yearly | Installation | action   |
| Check the ball bearings at the wind speed and direction sensors                     |           |             | X      | X            | (if the sensor is mechanical)                                |
| Check the balance staff of rain quantity sensor                                     |           | X           | X      | X            | (if the sensor is mechanical)                                |
| Check the functionality of rain status sensor                                       |           | X           | X      | X            |  |
| Inspection of cable and connectors between the measuring modules and data collector |           | X           | X      | X            |  |
| Functional check of the data collector  |           | X           | X      | X            |  |
| Check data transmission to the evaluation unit.                                     | X         | X           | X      | X            |  |
| <b>Communication</b>  |           |             |        |              |  |
| Communications-program upgrade  | X         | X           | X      | X            | if available   |
| Check the station specific setups and files   | X         | X           | X      | X            |  |
| Test the communication with central (bidirectional)                                 | X         | X           | X      | X            |  |
| Check the VPN router if included in the station                                     |           |             | X      | X            | For dust and dirt;<br>clean it dry, if necessary             |
| Check the VPN router if included in the station                                     |           |             | X      | X            | Check surface temperature! It should not be hotter than 50°C |
| Check the VPN router if included in the station                                     |           |             | X      | X            | Check the router for bad smell!<br>eg.: burnt electronics    |
|   |           |             |        |              |  |

**Document release**

|                                 |                  |
|---------------------------------|------------------|
| provided by: DI. Karoly Kautny  | date: 08.10.2008 |
| for contents: DI. Karoly Kautny | date: 08.10.2008 |
| Released by: Günter Kemminger   | date: 08.10.2008 |