

MANUAL
GAMMA MONITORING STATION
Type: BITT-GMS

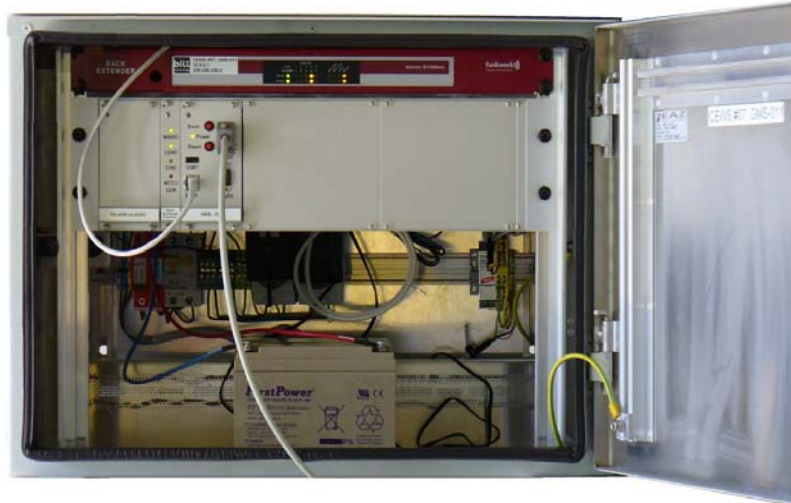

BITT Technology
Wienerstraße 70
A-2104 Spillern
Tel.: 0043/ 2266/ 80216
Fax.: 0043/ 2266/ 80216 12
office@bitt.at
www.bitt.at

MANUAL
GAMMA MONITORING STATION
Type: BITT-GMS
V.1.0
2010.05.03



Contents

1	IMPORTANT BASIC INFORMATION	5
1.1	ITEMS SUPPLIED	5
1.2	RESPONSIBILITIES	5
1.2.1	The manufacturer's responsibilities	5
1.2.2	The operating organization's responsibilities.....	5
1.3	LEGAL NOTES.....	6
1.4	SIGNIFICANCE OF THE OPERATING INSTRUCTIONS	7
2	SAFETY	8
2.1	BASIC SAFETY INSTRUCTIONS.....	8
2.1.1	Requirements on the personnel, duty to take due care.....	8
2.1.2	Electrical danger	8
2.1.3	Disposal	9
2.2	CORRECT USAGE.....	9
2.2.1	Application	9
2.2.2	Operating conditions.....	10
2.2.3	Connection conditions	10
2.3	INCORRECT USAGE	10
2.4	RESIDUAL HAZARDS AND PROTECTIVE MEASURES	10
3	TECHNICAL DATA.....	11
3.1	TECHNICAL DATA GMS.....	11
3.2	TECHNICAL DATA SURGE PROTECTION.....	13
3.3	TECHNICAL DATA SURGE PROTECTION FOR GAMMA-DETECTOR.....	14
3.4	TECHNICAL DATA SURGE PROTECTION FOR NETWORK	15
3.5	TECHNICAL DATA SURGE PROTECTION FOR NETWORK (ALTERNATIVE)	16
3.6	TECHNICAL DATA ROUTER	17
3.7	TECHNICAL DATA POWER SUPPLY	18
3.8	TECHNICAL DATA DEEP DISCHARGE PROTECTION.....	18
3.9	TECHNICAL DATA WEBDL-L / WEBDL2-L	19
3.9.1	Hardware features WebDL	19
3.9.2	Hardware features WebDL2	19
3.9.3	Software features.....	20
3.9.4	Hardware options.....	20
3.9.5	Software options	21
3.10	TECHNICAL DATA (OPTIONAL) BATTERY	22
4	LAYOUT AND FUNCTION	23
4.1	FUNCTIONAL DESCRIPTION.....	23
5	INSTALLATION CONDITIONS	24
5.1	AMBIENT CONDITIONS	24
5.2	SPACE REQUIRED.....	24
5.3	CONNECTION CONDITION	24
5.4	ODL CONNECTIONS (DISTRIBUTION FRAME).....	24
5.4.1	Electricity supply connection on WebDL(2)-L Backplane.....	25
5.4.2	WebDL(2)-L Backplane Connectors 1.....	25
5.4.3	WEBDL(2)-L Backplane Connectors 2	26
5.4.4	Router Connectors.....	26
5.5	CUSTOMER SAFETY PRECAUTIONS	26
6	OPERATION	27
6.1	CONTROLS (ONLY WITH WEBDL; WEBDL2).....	27
6.2	DISPLAYS AND WARNING DEVICES	27
6.3	SPECIAL TOOLS, EQUIPMENT, MATERIAL.....	27
6.4	PLACING IN SERVICE	27

6.5	ALIGNING, SETTING UP	27
6.6	OPERATING.....	28
6.7	INSTRUCTIONS ON THE DETECTION OF ERROR STATES.....	28
7	TROUBLESHOOTING.....	28
7.1	SERVICE ADDRESS	28
7.2	DIAGNOSTICS AND IDENTIFICATION OF ERROR STATES.....	28
8	MAINTENANCE.....	29
8.1	SERVICE ADDRESS	29
8.2	DEFINITION OF MAINTENANCE INTERVALS.....	29
8.3	REPAIR WORK	29
8.4	SPARE PARTS AND CONSUMABLES.....	30
	DOCUMENT RELEASE.....	31

1 Important basic information

1.1 Items supplied

- Cabinet including combined distribution frame
- Router incl. manual (optional)
- 230VAC power supply
- Deep discharge protection for backup battery
- WebDL-L or WebDL2-L incl. manual
 - 4-row LCD Display incl. 4-button keypad (optional)
 - Thermal printer incl. manual (optional)
- Backup battery (optional)
- Manual GMS

1.2 Responsibilities

1.2.1 The manufacturer's responsibilities

The ODL and the optional equipment was designed and built on the basis of a risk analysis and is under consideration of all relevant harmonized standards as well as further national standards and technical specifications. The system thus conforms to the current level of technology and guarantees the highest possible degree of safety.

1.2.2 The operating organization's responsibilities

The highest possible degree of safety can only be achieved in practice if all necessary measures are observed in dealing with the equipment. It is therefore part of the duty of care of the operator to plan these measures and check that they are executed correctly.

In particular the operator must ensure that

- the equipment only is used as prescribed (cf. chapter "Correct use"),

- the equipment is operated only in a fault-free, operational condition and in particular the safety devices are regularly checked to ensure that those function as stipulated,
- any necessary protective equipment or apparel for the operating, maintenance and repair personnel is available and is used,
- the operating manual is always legible and is available in full at the product's location,
- the product is operated, maintained and repaired only by sufficiently qualified and authorized personnel,
- the personnel is regularly instructed in all matters relating to occupational safety and environmental protection and is familiar with the operating manual and in particular the safety instructions that it contains.

1.3 Legal notes

The operating instructions must not be electronically or mechanically reproduced, distributed, amended, transmitted, translated into other languages or used in any other way – either in full or in part – without the express written approval of Bitt Technology-A Ges.m.b.H.

Bitt Technology-A Ges.m.b.H. shall not be liable for damage resulting from non-compliance with the operating instructions either in full or in part.

The information in this document is believed to be accurate in all respects at time of publication but is subject to change without notice. BITT Technology-A assumes no responsibility for errors and omissions, and disclaims responsibility for any consequences resulting from the use of information included herein. Additionally BITT Technology-A assumes no responsibilities for the functioning of undescribed features or parameters. BITT Technology reserves the right to make changes without further notice. BITT Technology make no warranty, representation or guarantee regarding the suitability of its products for any particular purpose, nor does BITT Technology assume any liability arising out of the application or use of any product and specifically disclaims any and all liability, including without limitation consequential or incidental damages. BITT Technology-A products are not designed, intended or authorized for use in applications intended to support or sustain life, or for any other application in which the failure of the BITT Technology-A product could create a situation where personal injury or death may occur. Should buyer purchase or use BITT Technology-A products for any such unintended or unauthorized application, buyer shall indemnify and hold BITT Technology harmless against all claims and damages.

BITT Technology, BITT Technology–A GesmbH are trademarks of BITT Technology–A Gesellschaft m.b.H.
Other products or brandnames mentioned herein are trademarks or registered trademarks of their respective holders.

1.4 Significance of the operating instructions

The operating instructions

- are part of the product,
- must be retained and maintained for the entire service life of the product (i.e. updated as necessary),
- must be passed to any subsequent owner or user of the product.

This document shall allow the customer to put an ODL into operation. But it is strongly recommended to get the help of someone who is familiar with networking and at best with Linux too.

For further information to the router see router manual, for further information to the WebDL see WebDL manual. Both additional manuals are scope of delivery.

2 Safety

2.1 Basic safety instructions

2.1.1 Requirements on the personnel, duty to take due care

- All work on the electrical equipment must be carried out by trained electrical specialists only.
- Electrical equipment must be checked regularly: Loose connections must be made secure, damaged wires or cables must be replaced immediately.
- All electrical supply units must always be kept locked. Access is only permitted for authorized persons.
- Never clean electrical apparatus with water or similar liquids.

The GMS is only permitted to be operated and maintained by personnel who has reached the minimum age stipulated by law.

A suitable qualified person is everyone who due to his/her specialist training, knowledge, and experience; as well as knowledge of the applicable stipulations, is able to assess the work assigned to him/her and can recognize possible hazards.

2.1.2 Electrical danger

When working on the equipment there is a risk of electrical danger from

- direct contact with live parts or parts which have become live due to faults,
- electrostatic processes,
- short circuits / overloading.

Batteries can present a risk of electric shock or burn from high short circuit current. The following precautions should be observed:

- Remove watches, rings, or other metal objects.
- Use tools with insulated handles.
- Do not lay tools or metal parts on top of batteries.

ELECTRICAL ENERGIE HAZARDS: Do not attempt to alter any battery wiring or connectors. Attempting to alter wiring can cause injury.

2.1.3 Disposal

Dispose of all components in accordance with locally applicable national regulations.

2.2 Correct usage

2.2.1 Application

The GMS is intended exclusively for:

- Acquiring data from directly connected measuring instruments like a gamma detector
- Data storage
- Visualizing data directly through a web server
- Log in to console over native serial port or ssh
- Using features described in chapter 3 “Technical data” and chapter 4 “Layout and function

Correct usage also includes reading this operating manual and complying with all the instructions it contains – in particular the safety instructions. Furthermore, all inspection and maintenance work must be carried out at the stipulated intervals.

The GMS is not designed for applications other than those listed here - this is considered as improper use!

If the GMS is not used in accordance with these conditions, safe operation of the equipment cannot be guaranteed.

For any injury or damage to persons or property resulting from improper use, the operator, but not the manufacturer of the system will be responsible!

2.2.2 Operating conditions

For consistent quality, it is imperative that the following ambient conditions are met.

Permissible room temperature: -20 °C to 70 °C

Permissible relative atmospheric humidity: 10 % to 90 % non-condensing

2.2.3 Connection conditions

Power connection for the optional power supply:

Voltage: 230V 1~/N/PE

Frequency: 50 Hz / 60 Hz

2.3 Incorrect usage

The GMS and the peripherals are not allowed to be modified or changed without approval.

The components of the GMS are not permitted to be integrated in other systems.

Maintenance work other than described in this manual only is permitted to be performed by Bitt technology personnel.

None of the operating conditions defined in correct usage are permitted to be changed.

2.4 Residual hazards and protective measures

- Electronic components can be damaged by electrostatic processes.
- The electrical components are not protected against water spray.
- Appropriate safety precautions must be taken by the customer.
- Prior to working on the electrical system unplug from the main or isolate the mains connection.
- Do not shortcut the optional battery (cf. chapter 2.1.2 “Electrical danger“)

3 Technical data

3.1 Technical data GMS

- Plug for RS03/X respectively RS04/X gamma detector
- Drop-out voltage bridge (backup battery)
- Battery, deep discharge protection
- Surge protection
- IP54 protection
- Anti-corrosion design (aluminum housing)
- Easy installation, separate mounting of the removable back cover
- Door hinge right or left possible

Dimensions:

Lx H x D in mm: 600 x 450 x 405

Weight (without accumulator incl. electronic equipment): 20kg (approximately)

Finish:

powder-coated aluminum, RAL 7035

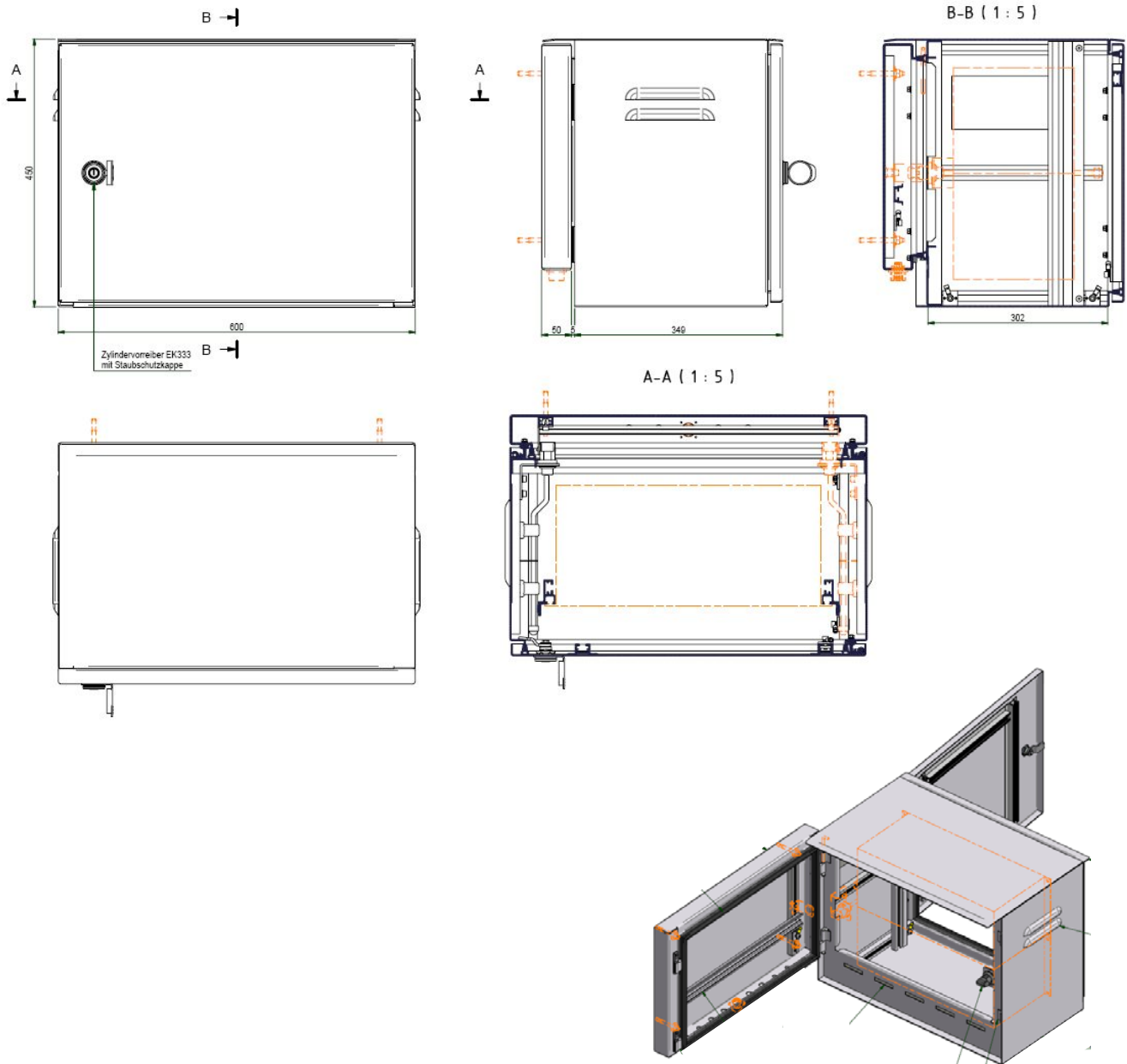

3.2 Technical data Surge protection

Type: DG M TT 2P 275

- 2-pole, modular surge arrester for single-phase 230VAC
- SPD Type 2 according to EN -11
- Base part with plug-in protection modules
- Easy exchange of protection modules with module release button
- DIN rail mounted device



Max. continuous voltage: 275VAC
Voltage protection level: $\leq 1.25\text{kV}$
Nominal discharge current: 20kA
Short circuit withstand capability: 50kArms

Dimensions:

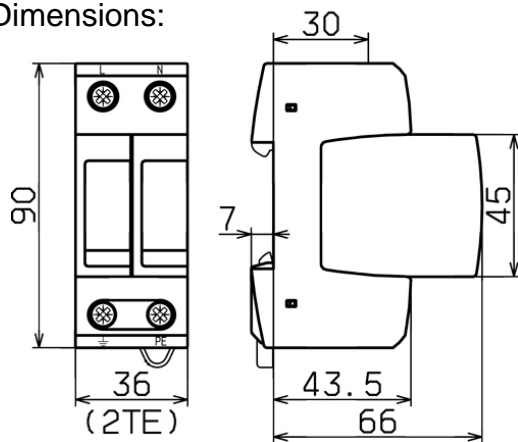

3.3 Technical data Surge protection for gamma-detector

Type: DCO RK ME 24

- Surge protective terminal block
- SPD class TYPE 2/P1, tested acc. to EN 61643-21,
- for protection of 2 single cores or unbalanced interfaces,
- 2-pole terminal, width: 6 mm, with spring pressure connection system
- DIN rail mounted device



Max. continuous voltage:	33VDC
Nominal current :	0.5A
C2 Total nominal discharge current (8/20 μ s):	10kA
Series impedance per line:	1.8ohms

Dimensions:

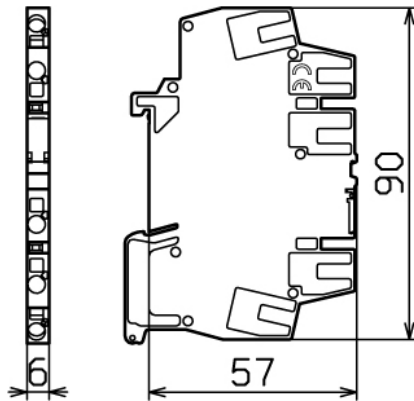

3.4 Technical data Surge protection for network

Type: BVT TC1

- Surge arrester BLITZDUCTOR VT
- SPD class TYPE 2/P2, tested acc. to EN 61643-21
- For the protection of analog modems in switchgear cabinets
- Also for ASDL, ISDN Uko, 2-pole
- RJ45(12)-socket
- DIN rail mounted device



Max. continuous voltage: 170VDC

Nominal current: 200mA

C2 Total nominal discharge current (8/20 μ s): 5kA

Dimensions:

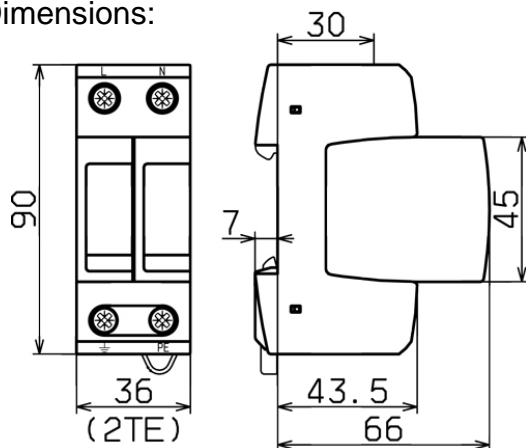

3.5 Technical data Surge protection for network (alternative)

Type: DPA M CLE RJ45B 48

- Surge arrester class E, fully shielded
- SPD class TYPE 2/P1, tested acc. to EN 61643-21
- For universal use according to EN 50173 up to 48 V DC for the protection of 4 pairs of data network interfaces via RJ45 socket.
- For single application or application in 19 inch cabinets, width 19 mm.



Max. continuous voltage: 48VDC

Nominal current: 1A

C2 Total nominal discharge current (8/20 μ s): 10kA

Dimensions:

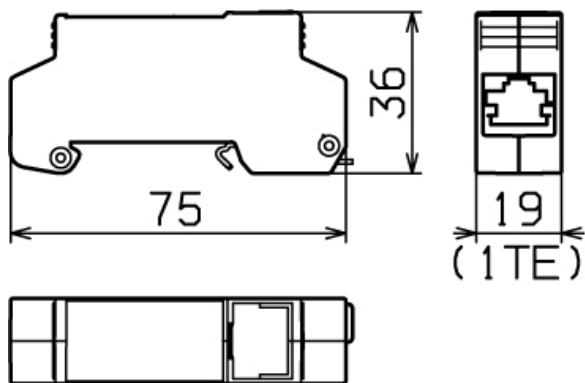

3.6 Technical data Router

Type: Funkwerk bintec 1200wu



Hardware Features

Feature	Description
RISC architecture	Motorola 8241 RISC processor with 32 MB RAM
Flash ROM	8 MB on board
4+1-port switch	4+1-port autosensing 10/100 Mbps Ethernet switch
VoIP DSP-Slot	Internal slot for 4 channel DSP
WLAN	Internal radio modul, 2,4 GHz and 5 GHz Band, 2 external antennas (Antenna Diversity)
ISDN	1 x BRI (2 B channels), opt. 2nd BRI via license
Console	Serial console port: RS 232 C, RJ45, 1,200 bps - 115 kbps
Power supply	External power supply 24 V DC
On/off switch	Available
Status LEDs	Power, Status, 10 x Ethernet, 8 x Function (ISDN, ADSL, WLAN, ...)
Housing	Metal housing
Card-Bus Slot	Slot with standard form factor, hot-plug capable
Current UMTS Card Support	OPTION GT 3G, OPTION GT 3G+, OPTION Globe Trotter 3G EDGE
19-inch	Optional: suitable for mounting in 19-inch cabinet via a 19-inch rack-mount kit
Fanless design	Long lifetime
Dimensions	Approx. 295 x 45 x 160 mm (W x H x D)

This is the specification of the standard router. It is mounted with an isolated plate (scope of delivery). For request there are other routers available. The cabinet provides 19" / 1 height unit space for the router.

For further information see router manual (scope of delivery)!

3.7 Technical data Power supply

Type: Bitt PS-40 W-14,0VDC

- Input: 100 – 240VAC, 1,2 A, 50-60 Hz
- Output nominal: 14VDC, 2,8 A
- Voltage adjustable range: 13,5 – 16,5 VDC



3.8 Technical data Deep discharge protection

Type: Bitt-DDP

Designed for lead acid battery with 12V nominal voltage.

Typical Ratings:

- Input (V+IN): 14VDC
- Battery voltage: 12 – 13,8VDC

Maximum Ratings:

- Input: 18VDC
- Battery voltage: 18VDC

Output: 5VDC max. 1A or 3A, depending on option



3.9 Technical data WebDL-L / WebDL2-L

Type: Bitt WebDL-L or WebDL2-L



WebDL-L / WebDL2-L

3.9.1 Hardware features WebDL

- ETRAX 100 LX MCM 4+16 CPU
- 32MB RAM
- 8MB Flash
- 1 Ethernet port 10/100Mbit
- 1 USB connector external or alternative native RS232
- 1 USB connector internal
- 2 native serial ports (RS232)
- 1 native RS232 port or alternative RS485/422
- MAXIM 1-wire interface connected to one RS232 port (alternatively over an external USB to 1-wire adapter)
- Real time clock (RTC), powered by an ultra capacitor (1 Farad), so changing of the battery isn't necessary!
- 4-row LCD Display incl. 4-button keypad (optional)

3.9.2 Hardware features WebDL2

- ARM CPU
- 64MB RAM
- 8MB Data flash (boot loader)
- SD Card / Mini SD Card
- 1 Ethernet port 10/100Mbit (PoE)
- 1 USB connector external
- 1 USB connector internal
- 3 native serial ports (RS232)
- 1 native RS232 port or alternative RS485/422
- 1 native RS232 port or alternative OLED



WebDL / WebDL2 board

- 1 native RS232 debug port
- MAXIM 1-wire interface connected to one RS232 port
- Real time clock (RTC), powered by an ultra capacitor (1 Farad), so changing of the battery isn't necessary!
- JTAG (optional)
- I2C (optional)
- 4-row LCD Display incl. 4-button keypad (optional)

3.9.3 Software features

- Running Linux (2.6.x).
- The acquired data are stored in a simple SQL database and/or files
- For specific purpose the "BITT-WEBDL can also provide the collected data through a FTP server.
- Every Browser can act as a client. The web page is optimized for MS Internet Explorer 6 or 7 but also tested with Firefox 3.x
- Support of SSL (https and SSH)
- Configuration of the station through the web page.
- Emergency and maintenance login over a console is provided at a native serial port.
- Login over Telnet and SSH is supported

3.9.4 Hardware options

- 230VAC power supply (optional)
- 4-row LCD Display incl. 4-button keypad (optional)
- Thermal printer (optional)
- Backup battery (optional)
- Deep discharge protection for backup battery (optional)
- Via USB it is possible to connect several peripherals like printers, displays and modems.

- Flash memory is easily expandable via a flash memory stick connected to the USB port.
- 10,4" / 12,1" / 15,1" TFT Display.

3.9.5 Software options

- Every data is visualized through a web server (optional)
- Charts and tables of every measured value (optional)
- Tables of status data via predefined queries or user defined queries (optional).
- Configuration of various alarm triggers. The alarm notification can be carried out by email and SMS (optional).
- Confirmation of every triggered alarm (optional).
- Changing and adding of languages is very easy. The whole web page is stored in a dictionary. So it is possible to add every desired language. By default the dictionary contains English and German (optional).
- Connections over SAMBA (e.g. MS Windows shares).
- Adapting the systems to special customer requirements is possible because Linux is used as operating system which offers many more features, than listed in this product folder!

WebDL2 and WebDL are compatible. For further information see WebDL manual (scope of delivery).

3.10 Technical data (optional) Battery

Type: First Power 12V 28Ah

Type: First Power 12V 12Ah

Dimension(mm)

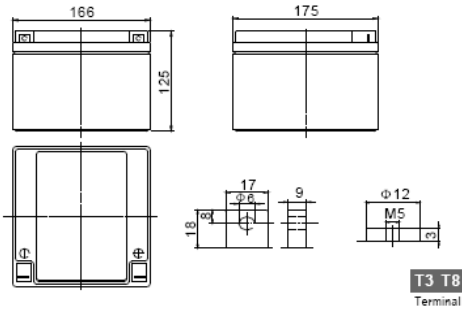

Specification

Nominal Voltage		12 V
Capacity(20HR, 25°C)		28Ah
Dimension	Length	166mm (6.54inch)
	Width	175mm (6.89inch)
	Height	125mm (4.92inch)
	Total Height(T3/T8)	125mm(4.92inch)/125mm(4.92inch)
Approx. Weight		9.0kg (19.9lbs)

Dimension(mm)

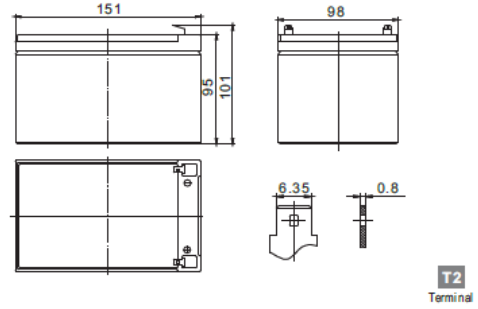

Specification

Nominal Voltage		12 V
Capacity(20HR, 25°C)		12Ah
Dimension	Length	151 mm (5.94inch)
	Width	98mm (3.86inch)
	Height	95mm (3.74inch)
	Total Height	101 mm (3.98inch)
Approx. Weight		3.60kg (8.14lbs)

(min. 7Ah – max. 100Ah)

4 Layout and function

4.1 Functional description

The GMS is a fixed-installed automatic gamma dose rate monitoring station for using with RS03 / X respectively RS04 / X gamma detector. Combined with WebDL and router it transfers the data automatically to networks, switches automatically to backup communications and provides additional data security and protection for hard- and software (e.g. drop-out voltage bridge, VPN). The configuration and the data query are operated via web interface.

The integrated router is used to forward data among computer networks beyond directly connected devices. Software and hardware, in combination, are customized to the tasks of routing and forwarding information.

The deep discharge protection (DDP) prevents the battery against deep discharging. If the Voltage of the battery becomes to low, the DDP disconnects the battery from the load. The DDP controls the charging voltage.

„BITT-WEBDL“ is a universal data logger consisting of hard- and software. The system is running an embedded Linux as operating system. It acquires data from directly connected measuring instruments like a gamma detector and stores these data. “BITT-WEBDL” is able to visualize data directly through a web server in a similar way as its big brother “BITT SCADA”.

5 Installation conditions

5.1 Ambient conditions

Read Chapter 2.2.2 "Operating conditions"

5.2 Space required

Read Chapter 3.1 "Technical data GMS"

5.3 Connection condition

Read Chapter 2.2.3 "Connection conditions"

5.4 ODL connections (distribution frame)

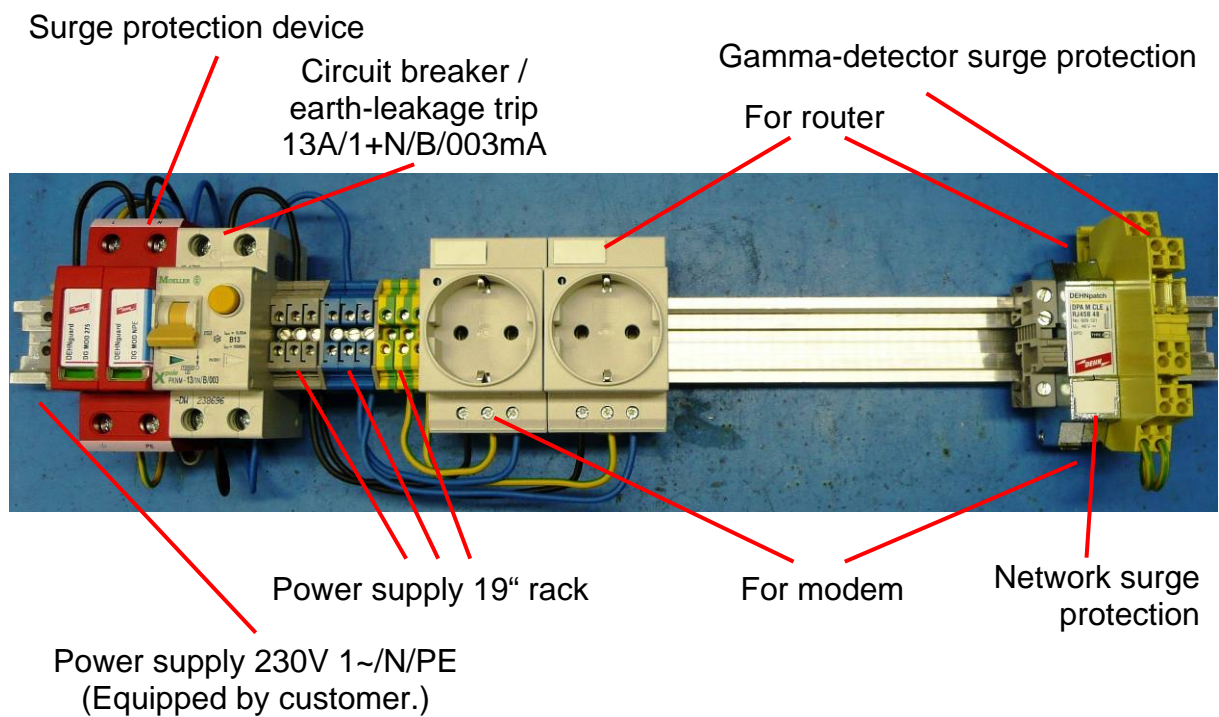

5.4.1 Electricity supply connection on WebDL(2)-L Backplane

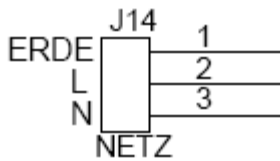

Voltage: 230V 1~/N/PE
Frequency: 50 Hz / 60 Hz

ERDE=PE
L=P
N=N

Fully cabled by the manufacturer.

5.4.2 WebDL(2)-L Backplane Connectors 1

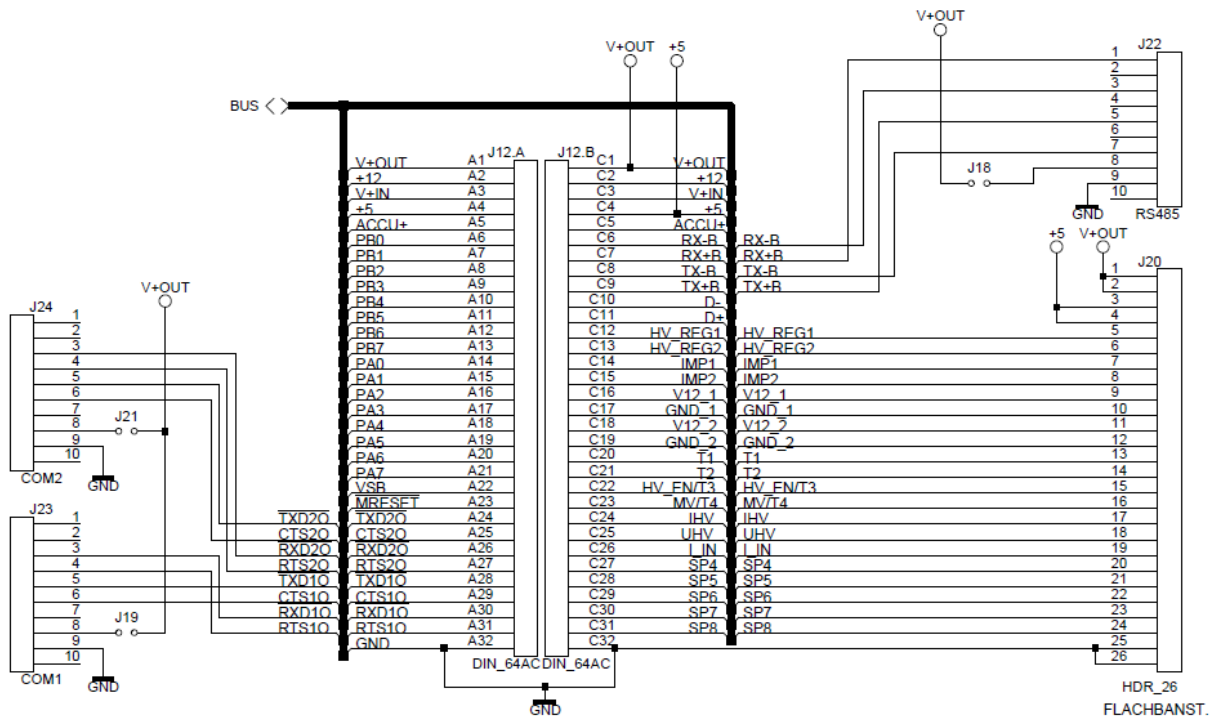

5.4.3 WEBDL(2)-L Backplane Connectors 2

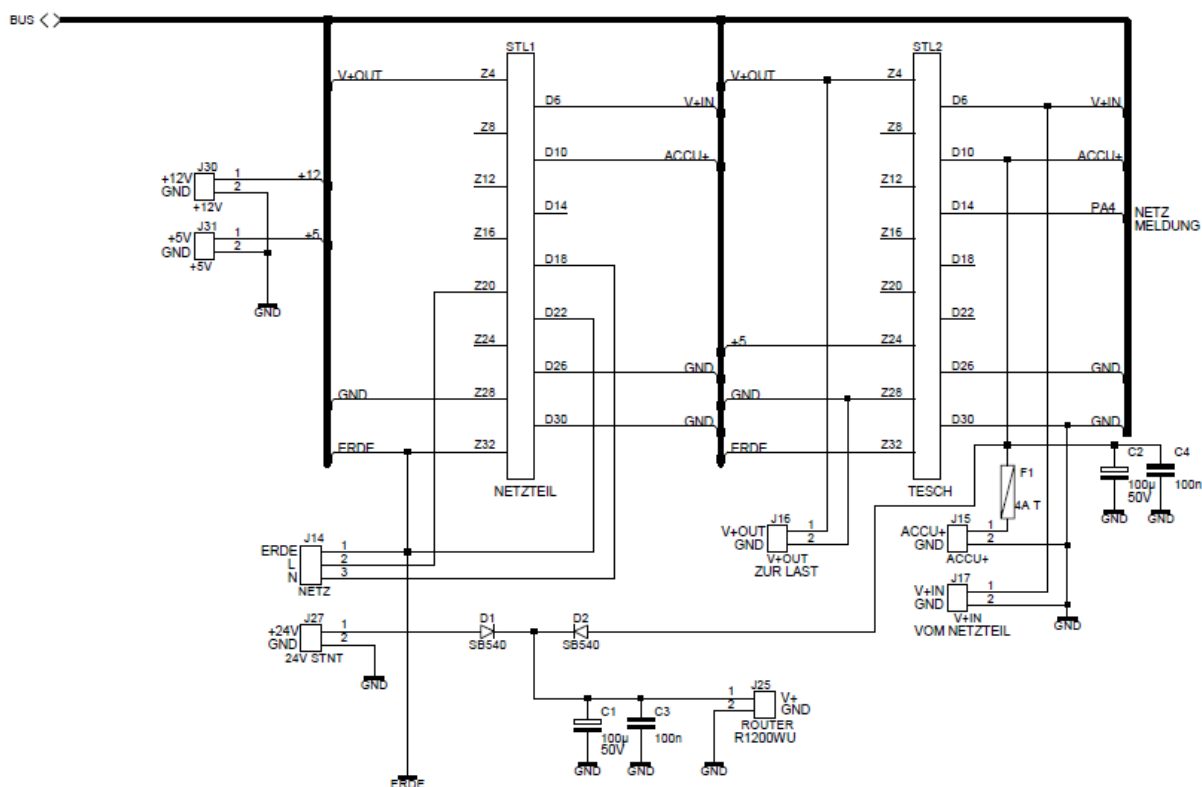

5.4.4 Router Connectors

The standard router (c.f. chapter 3.6 “Technical data Router”) is powered by the bus of the WebDL(2)-L backplane. For the power connection there is an additional cable with plug for the router fully cabled by the manufacturer. For other router types use one of the DIN rail power sockets on the distribution frame.

5.5 Customer safety precautions

Read chapter 2 “Safety”

6 Operation

6.1 Controls (only with WEBDL; WEBDL2)

- 4 row display (optional)
- 4 button keyboard (optional)
- Homepage of the devices (router and WebDL)
- SSH (encrypted console)
- Debug port (native console)
- Boot button (network flash mode)
- Reset button

6.2 Displays and warning devices

- Mains LED
- Load LED
- Charge LED
- Low (Battery) LED

6.3 Special tools, equipment, material

For complete configuration of the device an additional Laptop or Desktop-PC with network capability is required.

6.4 Placing in service

The device (re)starts automatically after power is (re-) established.

6.5 Aligning, setting up

See Router and WebDL manuals.

6.6 Operating

See router and WebDL manuals.

6.7 Instructions on the detection of error states

- By using (optional) display and look for errors
- Use SSH and check the display files
- Use central unit software Scada

See also Router and WebDL manuals.

7 Troubleshooting

7.1 Service address

BITT Technology
Wienerstraße 70
A-2104 Spillern

Tel.: 0043/ 2266/ 80216
Fax.: 0043/ 2266/ 80216 12

office@bitt.at
www.bitt.at

7.2 Diagnostics and identification of error states

Use debug port of WebDL for checking embedded Linux system messages.

Error message	Possible cause(s)	Rectification
(Optional) display without backlight	Screensaver after 60 seconds	Press a key of the 4 button keyboard
Mains LED dark (DDP)	Power failure	Check power line
All LEDs dark	Battery failure	Check battery and DDP

8 Maintenance

8.1 Service address

BITT Technology
Wienerstraße 70
A-2104 Spillern

Tel.: 0043/ 2266/ 80216
Fax.: 0043/ 2266/ 80216 12

office@bitt.at
www.bitt.at

8.2 Definition of maintenance intervals

- Generally if necessary
- Checking battery 1 time a year recommended

8.3 Repair work

Replace damaged devices.

8.4 Spare parts and consumables

Part nr.	Part name
0539	Female connector for probe
1283	DIN rail clamp yellow/green
1284	DIN rail clamp standard
1285	DIN rail clamp blue
2697	Cover D-UK 4/1
2712	DIN rail power socket
2746	Optional outdoor antenna (optional)
2932	Router (standard)
2933	Optional UMTS Card for R1200wu
3013	DIN rail bridge 10-pin
3063	Cable for DC power supply unit
3144	ODL Cabinet
3155	WebDL unit
3430	WebDL2 unit
3161	Cover D-UK 4/10 BU
3165	DC power supply unit
3178	Ring cable lug 6,6mm M5
3188	Deep discharge protection
3192	Surge protection
3196	Gamma-detector surge protection
3250	Network surge protection BVT TC 1
3197	Network surge protection DPA M CLE RJ45B 48
3200	End cover plate
3221	WebDL-L Rack
3241	Battery FP12280 12V28Ah
1261	Battery FP12120 12V12Ah
3242	Cable tree for GMS Cabinet
3263	Circuit breaker / earth-leakage trip
request	Thermal printer
request	4-row LCD Display incl. 4-button keypad

Document release

provided by: Martin Frühstück	date: 03.05.2010
for contents: Ing. Günter Kemminger	date: 04.05.2010
Released by: Ing. Günter Kemminger	date: 04.05.2010