

MANUAL
DATA LOGGER
Type: BITT-WEBDL-L/-M/-S



BITT Technology
Wienerstraße 70
A-2104 Spillern
Tel.: 0043/ 2266/ 80216
Fax.: 0043/ 2266/ 80216 12
office@bitt.at
www.bitt.at

MANUAL
DATA LOGGER
Type: BITT-WEBDL-L/-M/-S
V.1.0
2010.04.27



Contents

1	IMPORTANT BASIC INFORMATION	5
1.1	ITEMS SUPPLIED	5
1.2	RESPONSIBILITIES	5
1.2.1	The manufacturer's responsibilities	5
1.2.2	The operating organization's responsibilities.....	5
1.3	LEGAL NOTES	6
1.4	SIGNIFICANCE OF THE OPERATING INSTRUCTIONS	7
2	SAFETY	7
2.1	BASIC SAFETY INSTRUCTIONS.....	7
2.1.1	Requirements on the personnel, duty to take due care.....	7
2.1.2	Electrical danger	8
2.1.3	Disposal	8
2.2	CORRECT USAGE.....	8
2.2.1	Application	8
2.2.2	Operating conditions.....	9
2.2.3	Connection Conditions.....	9
2.3	INCORRECT USAGE	9
2.4	RESIDUAL HAZARDS AND PROTECTIVE MEASURES	9
3	TECHNICAL DATA.....	10
3.1	TECHNICAL DATA CABINET WEBDL-L.....	10
3.2	TECHNICAL DATA 19" RACK WEBDL-L.....	11
3.3	TECHNICAL DATA CABINET WEBDL-M.....	12
3.4	TECHNICAL DATA CABINET WEBDL-S	13
3.5	TECHNICAL DATA POWER SUPPLY WEBDL-L	14
3.6	TECHNICAL DATA POWER SUPPLY WEBDL-M / -S.....	14
3.7	TECHNICAL DATA DEEP DISCHARGE PROTECTION	14
3.8	TECHNICAL DATA WEBDL	15
3.8.1	Hardware features	15
3.8.2	Software features.....	16
3.8.3	Hardware Options.....	16
3.8.4	Software Options	17
3.9	TECHNICAL DATA OPTIONAL BACKUP BATTERY WEBDL-L.....	17
4	LAYOUT AND FUNCTION	18
4.1	FUNCTIONAL DESCRIPTION.....	18
4.1.1	Block diagram Bitt-WebDL.....	18
4.1.2	DP chart Bitt-WebDL	19
5	INSTALLATION CONDITIONS	19
5.1.1	WebDL-L Electricity supply connections	19
5.1.2	WebDL-L Backplane Connectors 1	20
5.1.3	WebDL-L Backplane Connectors 2	20
5.1.4	WebDL-L 230VAC power supply 19" version	21
5.1.5	Connections WebDL at the front of the module.....	21
5.1.6	Connections WebDL internal.....	22
5.1.7	WebDL Board male multipoint connector on back side.....	26
5.2	CUSTOMER SAFETY PRECAUTIONS	26
6	OPERATION	27
6.1	CONTROLS.....	27
6.2	DISPLAYS AND WARNING DEVICES	27
6.3	OPERATING MODES	27
6.3.1	Data logger mode	27
6.3.2	Direct Data mode.....	28

6.4	SPECIAL TOOLS, EQUIPMENT, MATERIAL.....	28
6.5	PLACING IN SERVICE.....	28
6.6	ALIGNING, SETTING UP.....	28
6.6.1	Assigning an IP address via DHCP.....	28
6.6.2	Assigning an IP address manually.....	28
6.7	OPERATING.....	30
6.7.1	Basic configuration.....	30
6.7.2	Network configuration.....	32
6.7.3	Configuration in data logger mode.....	32
6.7.4	Special direct data operation mode.....	33
6.7.5	Files and directories in data logger mode.....	37
6.7.6	File format in data logger mode.....	38
6.7.7	File Format in Data Logger detailed.....	39
6.8	OPTIONAL LCD DISPLAY.....	41
6.8.1	General menu navigation.....	42
6.8.2	Menu structure part 1.....	43
6.8.3	Menu structure part 2.....	44
6.8.4	Menu structure part 3.....	45
6.8.5	Menu structure part 4.....	46
6.9	INSTRUCTIONS ON THE DETECTION OF ERROR STATES.....	47
7	TROUBLESHOOTING.....	47
7.1	SERVICE ADDRESS.....	47
7.2	DIAGNOSTICS AND IDENTIFICATION OF ERROR STATES.....	47
8	MAINTENANCE.....	48
8.1	SERVICE ADDRESS.....	48
8.2	DEFINITION OF MAINTENANCE INTERVALS.....	48
8.3	REPAIR WORK.....	48
8.4	SPARE PARTS AND CONSUMABLES.....	48
	DOCUMENT RELEASE.....	49

1 Important basic information

1.1 Items supplied

	WebDL-L	WebDL-M	WebDL-S
Cabinet	● (L)	● (M)	● (S)
230VAC power supply	● (internal)	● (external)	● (external)
Deep discharge protection for backup battery	●	--	--
WebDL board	●	●	●
4-row LCD Display incl. 4-button keypad (optional)	○	○	○
Thermal printer	○	--	--
Backup battery	○ (external)	--	--
Manual	●	●	●

● supplied ○ optional -- not supplied

1.2 Responsibilities

1.2.1 The manufacturer's responsibilities

The WebDL and the optional equipment was designed and built on the basis of a risk analysis and is under consideration of all relevant harmonized standards as well as further national standards and technical specifications. The system thus conforms to the current level of technology and guarantees the highest possible degree of safety.

1.2.2 The operating organization's responsibilities

The highest possible degree of safety can only be achieved in practice if all necessary measures are observed in dealing with the equipment. It is therefore part of the duty of care of the operator to plan these measures and check that they are executed correctly.

In particular the operator must ensure that

- the equipment only is used as prescribed (cf. chapter 2.2 "Correct usage"),
- the equipment is operated only in a fault-free, operational condition and in particular the safety devices are regularly checked to ensure that those function as stipulated,

- any necessary protective equipment or apparel for the operating, maintenance and repair personnel is available and is used,
- the operating manual is always legible and is available in full at the product's location,
- the product is operated, maintained and repaired only by sufficiently qualified and authorized personnel,
- the personnel is regularly instructed in all matters relating to occupational safety and environmental protection and is familiar with the operating manual and in particular the safety instructions that it contains.

1.3 Legal notes

The operating instructions must not be electronically or mechanically reproduced, distributed, amended, transmitted, translated into other languages or used in any other way – either in full or in part – without the express written approval of Bitt Technology-A Ges.m.b.H.

Bitt Technology-A Ges.m.b.H. shall not be liable for damage resulting from non-compliance with the operating instructions either in full or in part.

The information in this document is believed to be accurate in all respects at time of publication but is subject to change without notice. BITT Technology-A assumes no responsibility for errors and omissions, and disclaims responsibility for any consequences resulting from the use of information included herein. Additionally BITT Technology-A assumes no responsibilities for the functioning of undescribed features or parameters. BITT Technology reserves the right to make changes without further notice. BITT Technology make no warranty, representation or guarantee regarding the suitability of its products for any particular purpose, nor does BITT Technology assume any liability arising out of the application or use of any product and specifically disclaims any and all liability, including without limitation consequential or incidental damages. BITT Technology-A products are not designed, intended or authorized for use in applications intended to support or sustain life, or for any other application in which the failure of the BITT Technology-A product could create a situation where personal injury or death may occur. Should buyer purchase or use BITT Technology-A products for any such unintended or unauthorized application, buyer shall indemnify and hold BITT Technology harmless against all claims and damages.

BITT Technology, BITT Technology–A GesmbH are trademarks of BITT Technology–A Gesellschaft m.b.H.
Other products or brandnames mentioned herein are trademarks or registered trademarks of their respective holders.

1.4 Significance of the operating instructions

The operating instructions

- are part of the product,
- must be retained and maintained for the entire service life of the product (i.e. updated as necessary),
- must be passed to any subsequent owner or user of the product.

This document shall allow the customer to put a WebDL-X device into operation. But it is strongly recommended to get the help of someone who is familiar with networking and at best with Linux too.

2 Safety

2.1 Basic safety instructions

2.1.1 Requirements on the personnel, duty to take due care

- All work on the electrical equipment must be carried out by trained electrical specialists only.
- Electrical equipment must be checked regularly: Loose connections must be made secure, damaged wires or cables must be replaced immediately.
- All electrical supply units must always be kept locked. Access is only permitted for authorized persons.
- Never clean electrical apparatus with water or similar liquids.

The WebDL-X is only permitted to be operated and maintained by personnel who has reached the minimum age stipulated by law.

A suitable qualified person is everyone who is due to his/her specialist training, knowledge, and experience; as well as knowledge of the applicable stipulations, is able to assess the work assigned to him/her and can recognize possible hazards.

2.1.2 Electrical danger

When working on the equipment there is a risk of electrical danger from

- direct contact with live parts or parts which have become live due to faults,
- electrostatic processes,
- short circuits / overloading.

Batteries can present a risk of electric shock or burn from high short circuit current. The following precautions should be observed:

- Remove watches, rings, or other metal objects.
- Use tools with insulated handles.
- Do not lay tools or metal parts on top of batteries.

ELECTRICAL ENERGIE HAZARDS: Do not attempt to alter any battery wiring or connectors. Attempting to alter wiring can cause injury.

2.1.3 Disposal

Dispose of all components in accordance with locally applicable national regulations.

2.2 Correct usage

2.2.1 Application

The WebDL is intended exclusively for:

- Acquiring data from directly connected measuring instruments like a gamma detector.
- Data storage.
- Visualizing data directly through a web server.
- Log in to console over native serial port or ssh.

Correct usage also includes reading this operating manual and complying with all the instructions it contains – in particular the safety instructions. Furthermore, all inspection and maintenance work must be carried out at the stipulated intervals.

The WebDL-X is not designed for applications other than those listed here - this is considered as improper use!

If the WebDL-X is not used in accordance with these conditions, safe operation of the equipment cannot be guaranteed.

For any injury or damage to persons or property resulting from improper use, the operator, but not the manufacturer of the system will be responsible!

2.2.2 Operating conditions

For consistent quality, it is imperative that the following ambient conditions are met.

Permissible room temperature: -20 °C to 70 °C

Permissible relative atmospheric humidity: 10 % to 90 % non-condensing

2.2.3 Connection Conditions

Power connection for the optional power supply:

Voltage: 230V 1~/N/PE

Frequency: 50 Hz / 60 Hz

2.3 Incorrect usage

The WebDL and the peripherals are not allowed to be modified or changed without approval.

The components of the WebDL are not permitted to be integrated in other systems.

Maintenance work other than described in this manual only is permitted to be performed by Bitt technology personnel.

None of the operating conditions defined in correct usage are permitted to be changed.

2.4 Residual hazards and protective measures

- Electronic components can be damaged by electrostatic processes.
- The electrical components are not protected against water spray.
- Appropriate safety precautions must be taken by the customer.

- Prior to working on the electrical system unplug from the main or isolate the mains connection.
- Do not shortcut the optional battery (cf. chapter 2.1.2 “Electrical danger“)

3 Technical data

3.1 Technical data cabinet WebDL-L

Dimensions:

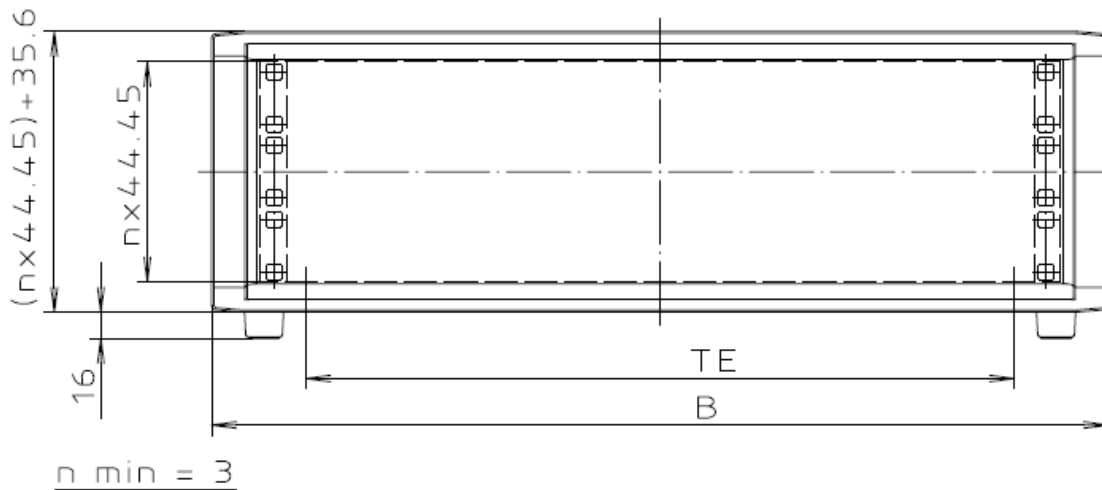

T (mm)	TE	B	b1	b2
350	84	540	486	467

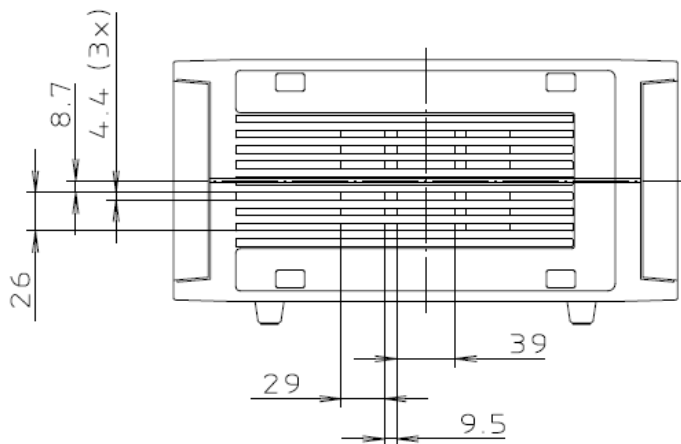

3.2 Technical data 19" Rack WebDL-L

Dimensions (19" Rack):

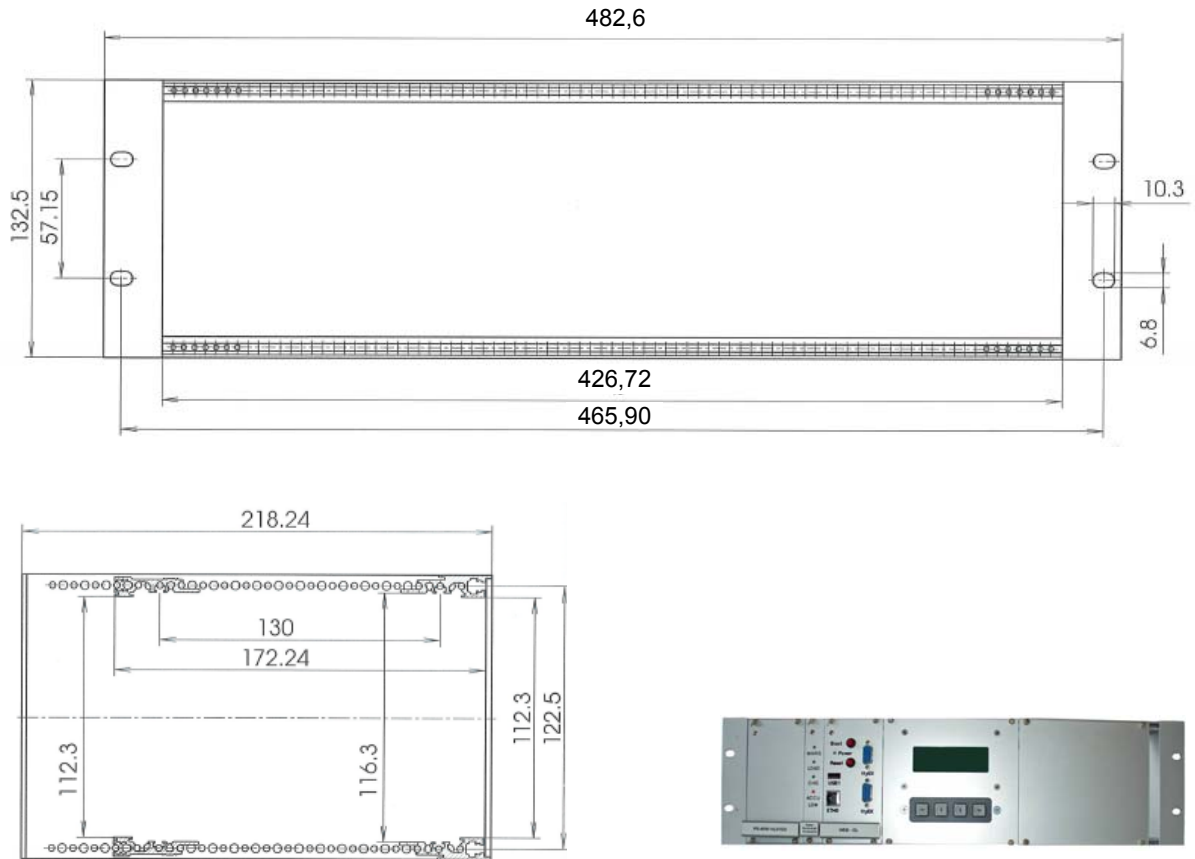

3.3 Technical data cabinet WebDL-M

Dimensions:

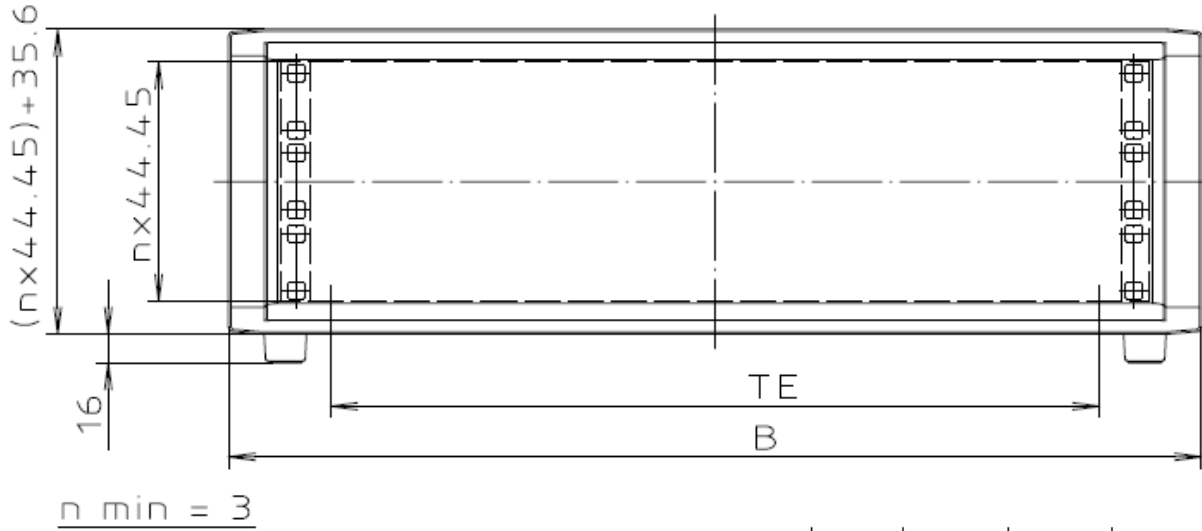

T(mm)	TE	B	b1	b2
250	42	327	272	253

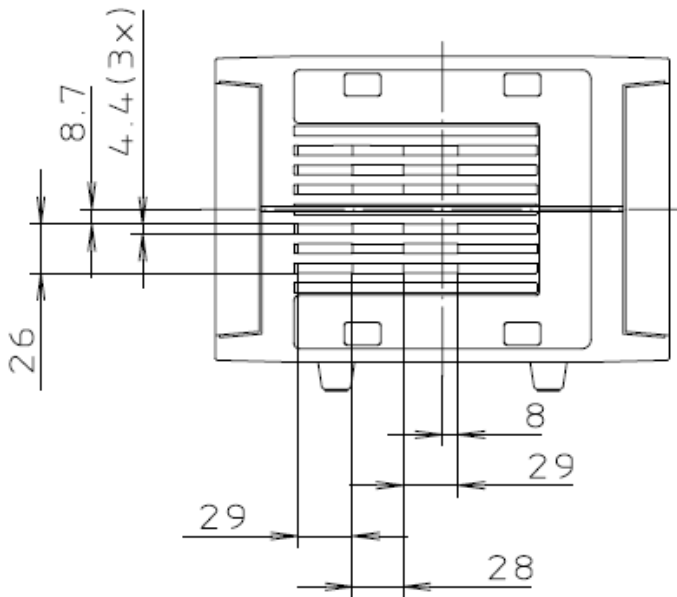

3.5 Technical data Power supply WebDL-L

Type: Bitt PS-40 W-14,0VDC

- Input: 100 – 240VAC, 1,2 A, 50-60 Hz
- Output nominal: 14VDC, 2,8 A
- Voltage adjustable range: 13,5 – 16,5 VDC



3.6 Technical data Power Supply WebDL-M / -S

- Input: 230VAC, 300mA, 47-63Hz
- Output nominal: 24VDC, 1A

or

- Input: 100-240VAC, 1A, 50-60Hz
- Output nominal: 15VDC, 2,4A



3.7 Technical data Deep discharge protection

Type: Bitt-DDP

Designed for lead acid battery with 12V nominal voltage.

Typical Ratings:

- Input (V+IN): 14VDC
- Battery voltage: 12 – 13,8VDC

Maximum Ratings:

- Input: 18VDC
- Battery voltage: 18VDC
- Output: 5VDC max. 1A or 3A, depending on option



3.8 Technical data WebDL

Type: Bitt WebDL

3.8.1 Hardware features

- ETRAX 100 LX MCM 4+16 CPU
- 32MB RAM
- 8MB Flash
- 1 Ethernet port 10/100Mbit
- 1 USB connector external or alternative native RS232
- 1 USB connector internal
- 2 native serial ports (RS232)
- 1 native RS232 port or alternative RS485/422
- MAXIM 1-wire interface connected to one RS232 port (alternatively over an external USB to 1-wire adapter)
- Real time clock (RTC), powered by an ultra capacitor (1 Farad), so changing of the battery isn't necessary!
- 4-row LCD Display incl. 4-button keypad (optional)



3.8.2 Software features

- Running Linux (2.6.x).
- The acquired data are stored in a simple SQL database and/or files
- For specific purpose the “BITT-WEBDL can also provide the collected data through a FTP server.
- Every Browser can act as a client. The web page is optimized for MS Internet Explorer 6 or 7 but also tested with Firefox 3.x
- Support of SSL (https and SSH)
- Configuration of the station through the web page.
- Emergency and maintenance login over a console is provided at a native serial port.
- Login over Telnet and SSH is supported

3.8.3 Hardware Options

- 230VAC power supply (optional)
- 4-row LCD Display incl. 4-button keypad (optional)
- Thermal printer (optional)
- Backup battery (optional)
- Deep discharge protection for backup battery (optional)
- Via USB it is possible to connect several peripherals like printers, displays and modems.
- Flash memory is easily expandable via a flash memory stick connected to the USB port.
- 10,4” / 12,1” / 15,1” TFT Display.

3.8.4 Software Options

- Every data is visualized through a web server (optional)
- Charts and tables of every measured value (optional)
- Tables of status data via predefined queries or user defined queries (optional).
- Configuration of various alarm triggers. The alarm notification can be carried out by email and SMS (optional).
- Confirmation of every triggered alarm (optional).
- Changing and adding of languages is very easy. The whole web page is stored in a dictionary. So it is possible to add every desired language. By default the dictionary contains English and German (optional).
- Connections over SAMBA (e.g. MS Windows shares).
- Adapting the systems to special customer requirements is possible because Linux is used as operating system which offers many more features, than listed in this product folder!

3.9 Technical data optional backup battery WebDL-L

Type: First Power 12V 28Ah

Type: First Power 12V 12Ah

Dimension(mm)

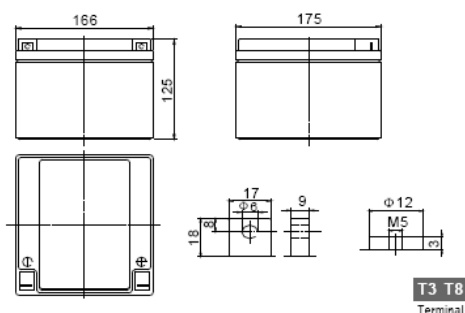

Specification

Nominal Voltage		12 V
Capacity(20HR, 25°C)		28Ah
Dimension	Length	166mm (6.54inch)
	Width	175mm (6.89inch)
	Height	125mm (4.92inch)
Total Height(T3/T8)		125mm(4.92inch)/125mm(4.92inch)
Approx. Weight		9.0kg (19.9lbs)

Dimension(mm)

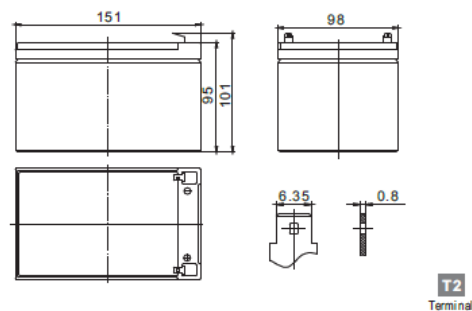

Specification

Nominal Voltage		12 V
Capacity(20HR, 25°C)		12Ah
Dimension	Length	151mm (5.94inch)
	Width	98mm (3.86inch)
	Height	95mm (3.74inch)
Total Height		101mm (3.98inch)
Approx. Weight		3.60kg (8.14lbs)

(min. 7Ah – max. 100Ah)

4 Layout and function

4.1 Functional description

The integrated “Bitt-WebDL” is a universal data logger consisting of hard- and software. The data logger is based on a CPU (ETRAX 100LX MCM 4+16) from AXIS. The system is running an embedded Linux as operating system. It acquires data from directly connected measuring instruments like a gamma detector and stores these data. “Bitt-WebDL” is able to visualize data directly through a web server in a similar way as its big brother “BITT SCADA”.

The deep discharge protection (DDP) prevents the battery against deep discharging. If the Voltage of the battery becomes to low, the DDP disconnects the battery from the load. The DDP controls the charging voltage.

4.1.1 Block diagram Bitt-WebDL

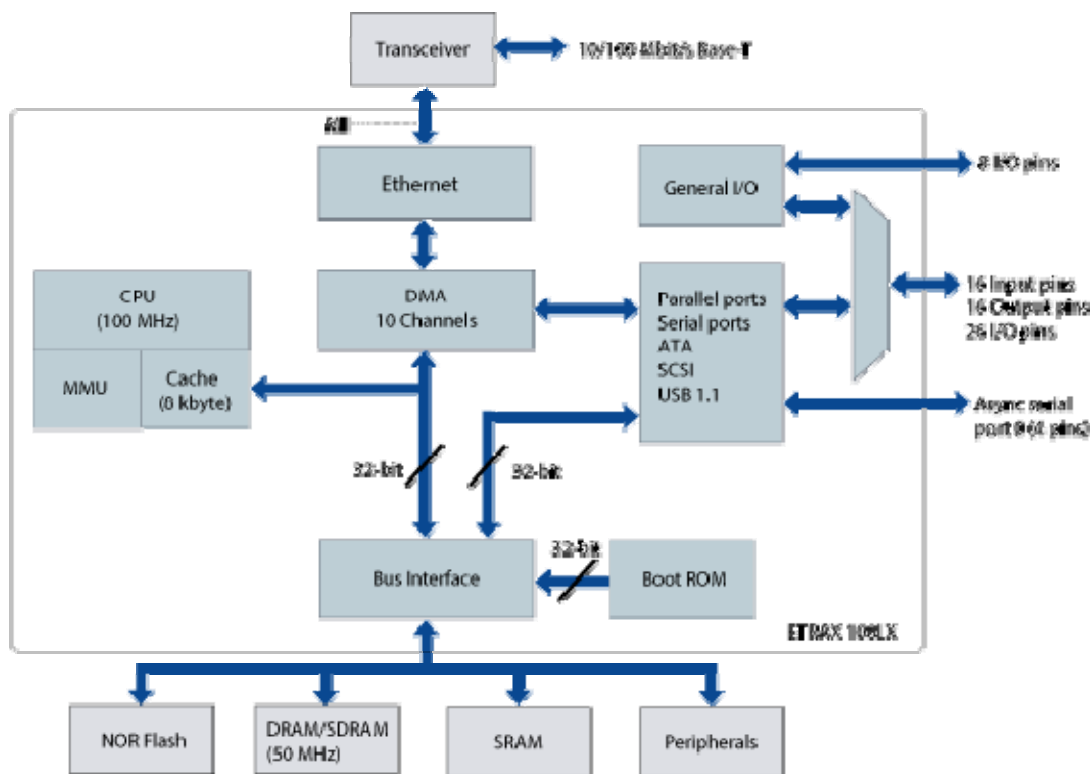

4.1.2 DP chart Bitt-WebDL

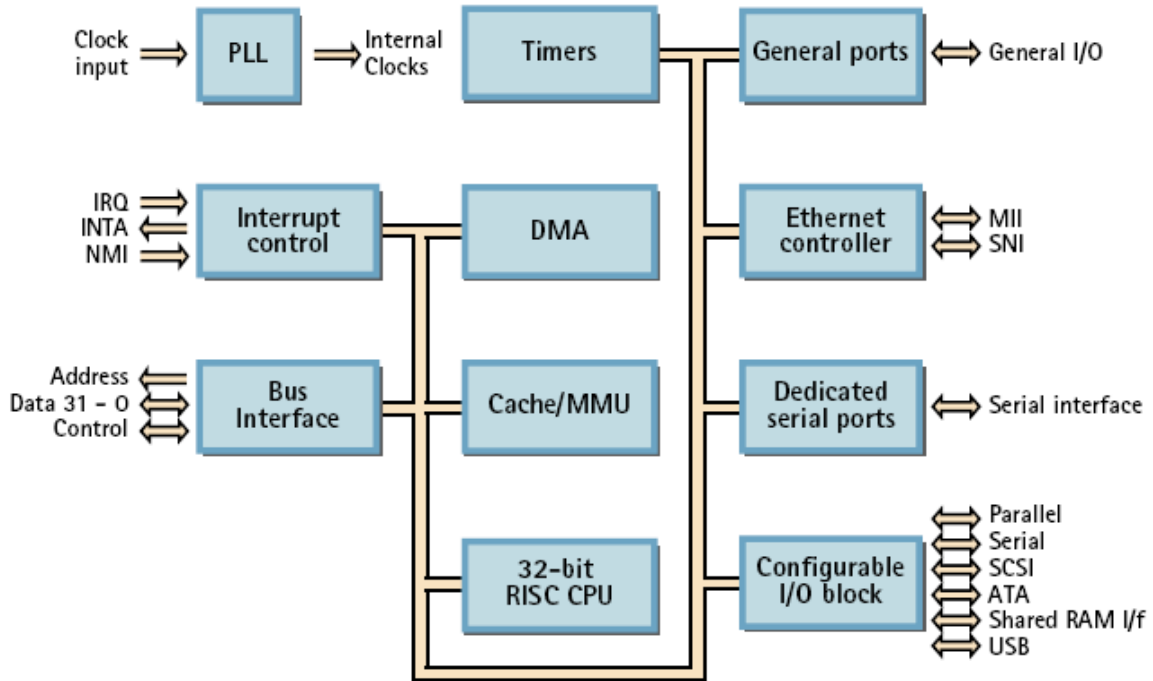

5 Installation conditions

5.1.1 WebDL-L Electricity supply connections

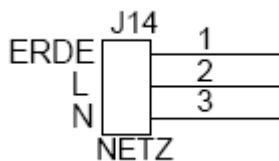

Voltage: 230V 1~/N/PE
Frequency: 50 Hz / 60 Hz

ERDE=PE
L=P
N=N

5.1.4 WebDL-L 230VAC power supply 19" version

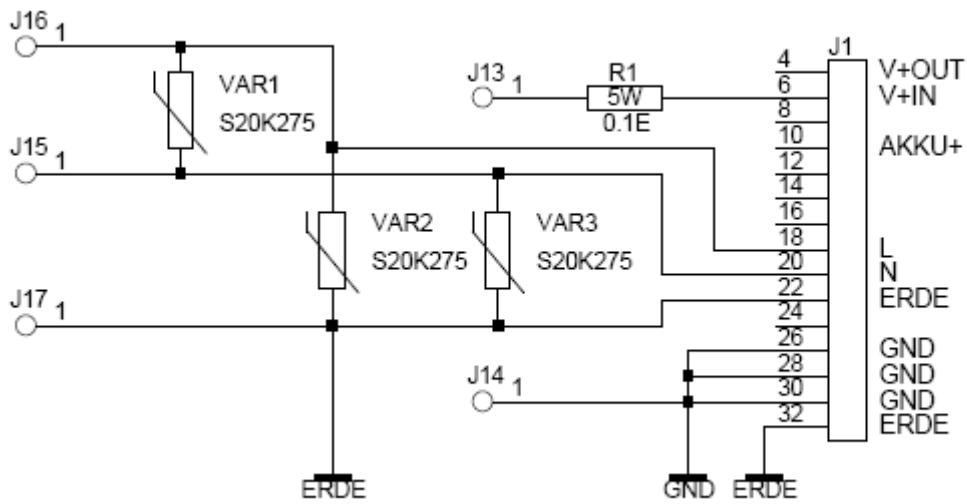

5.1.5 Connections WebDL at the front of the module

5.1.5.1 RS232 ttyS0 / debug serial port

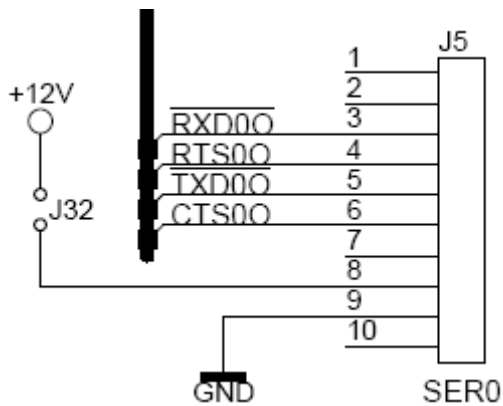

5.1.5.2 RS234 ttyS2

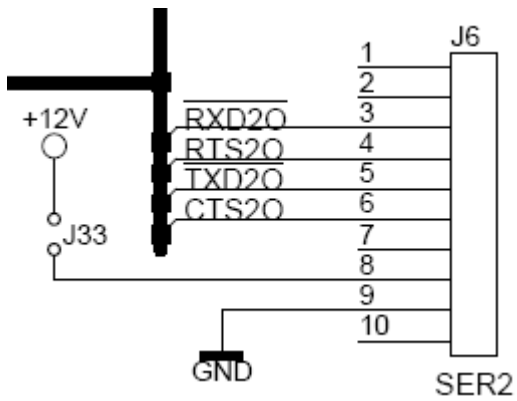

5.1.5.3 Front USB1

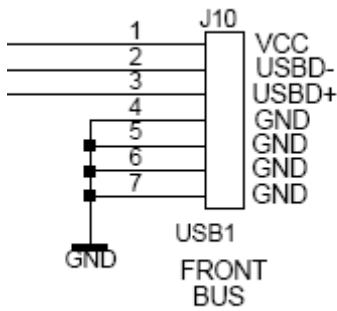

5.1.6 Connections WebDL internal

5.1.6.1 RS232 ttyS1

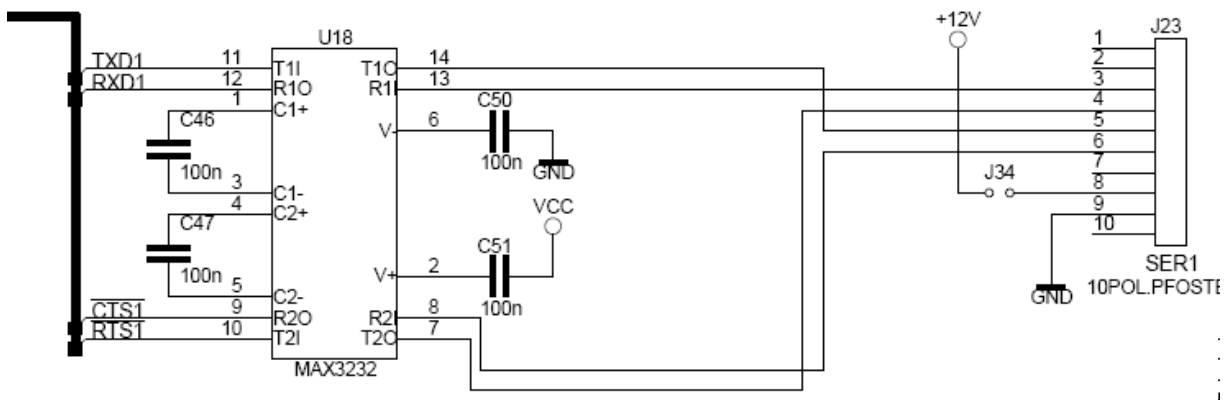

5.1.6.2 MAXIM DALLAS one wire interface (3 connectors available)

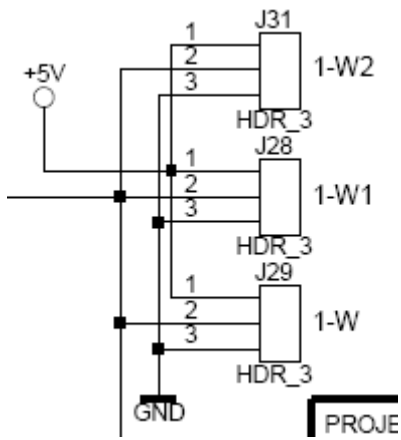

5.1.6.3 RS232/RS485/RS422 ttyS3 (specify at order!, mounting option!)

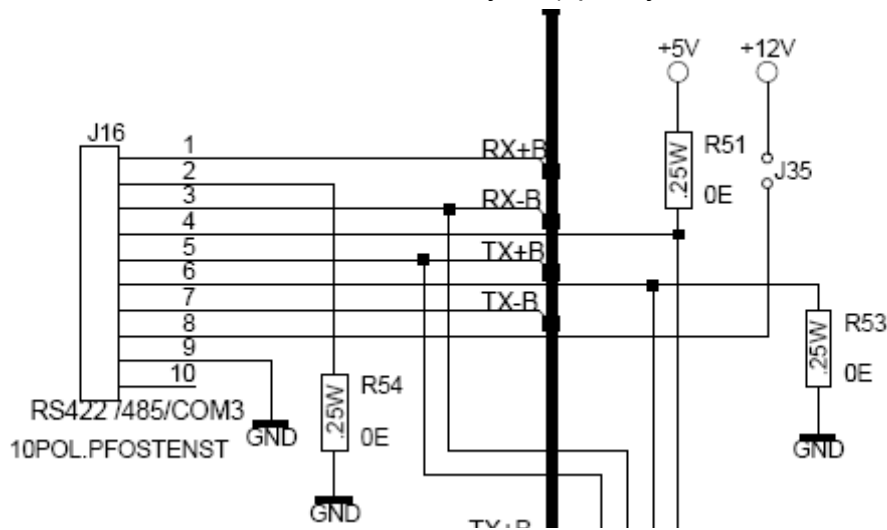

5.1.6.4 Tub stripe connector for „4 button keyboard“ and „GPIO“

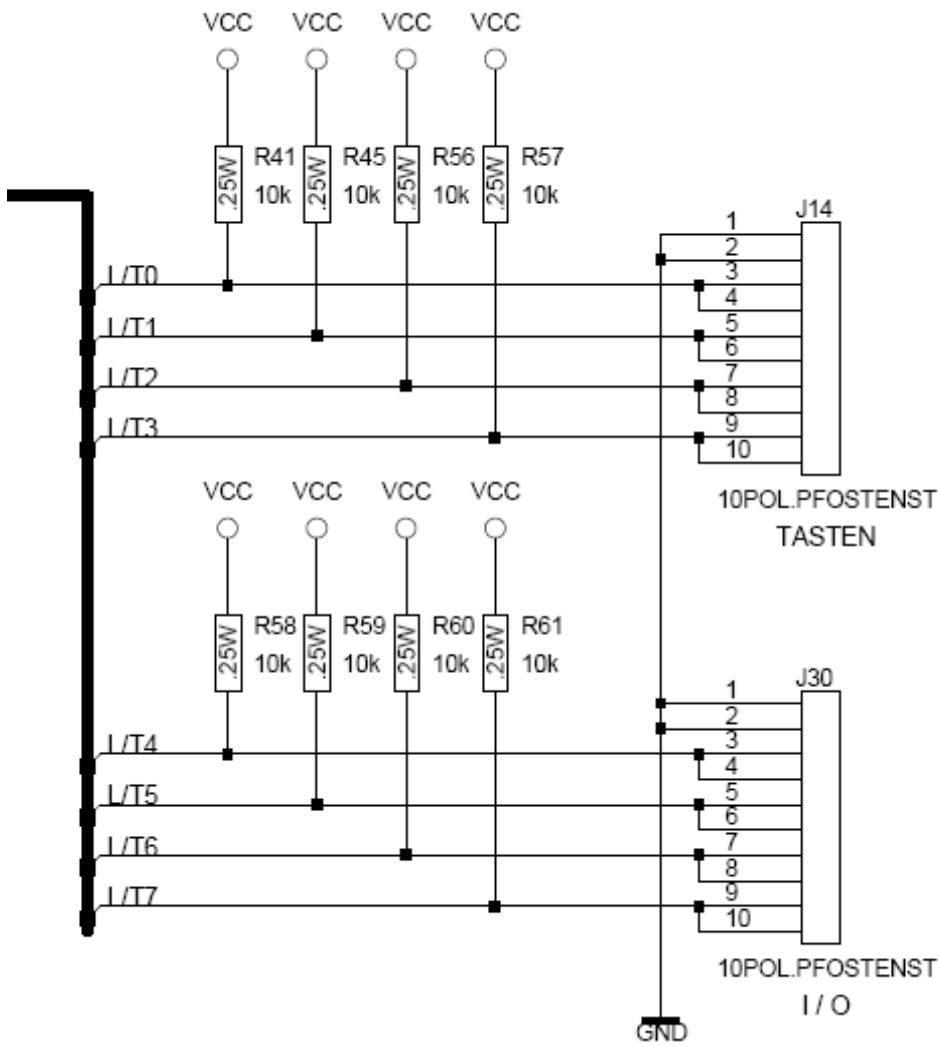

5.1.6.5 Tub stripe connector for „4 row LCD“

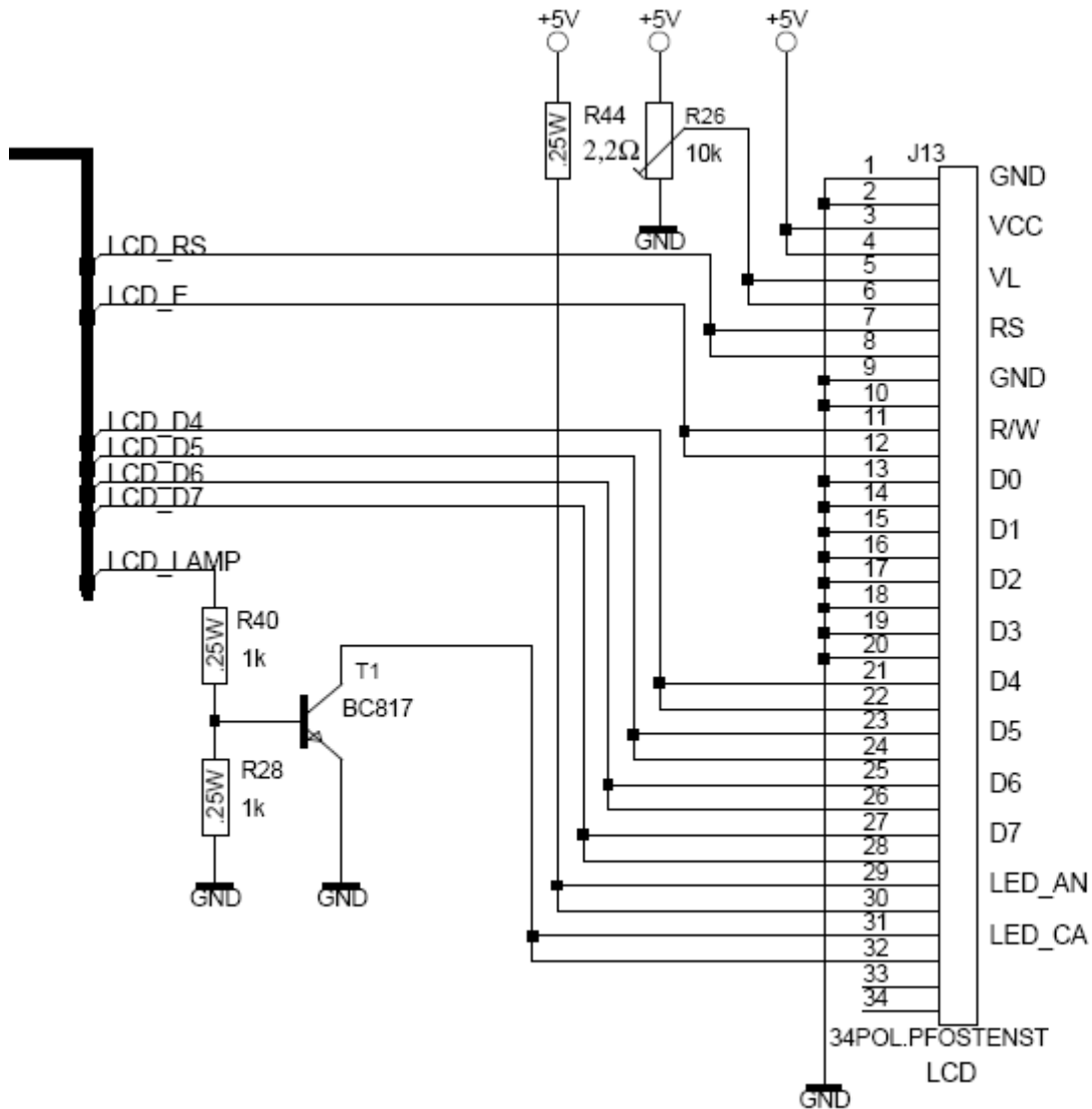

5.1.6.6 Internal USB2

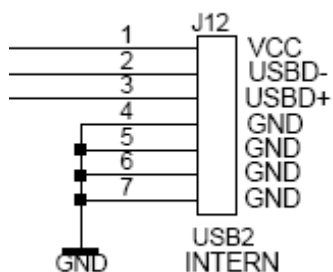

5.1.7 WebDL Board male multipoint connector on back side

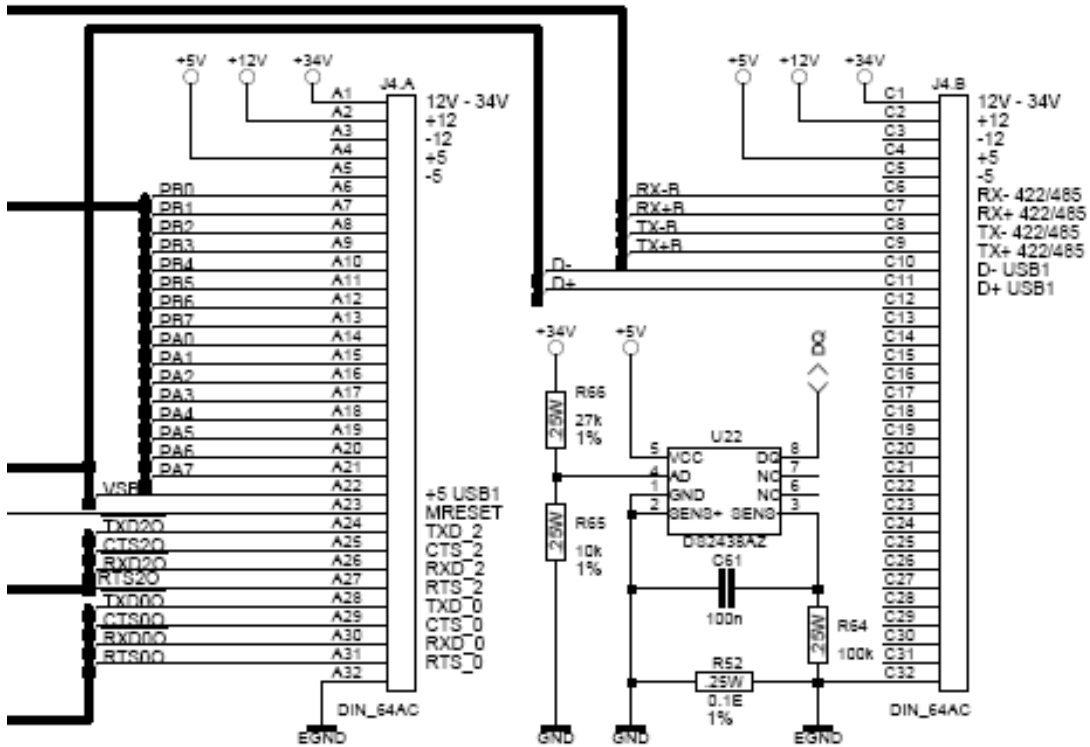

5.2 Customer safety precautions

Read chapter 2 “Safety”

6 Operation

6.1 Controls

- 4 row display (optional)
- 4 button keyboard (optional)
- Homepage of the device
- SSH (encrypted console)
- Debug port (native console)
- Boot button (network flash mode)
- Reset button

6.2 Displays and warning devices

- Mains LED
- Load LED
- Charge LED
- Low (Battery) LED

6.3 Operating modes

There are two modes of operation available, which are completely different!

6.3.1 Data logger mode

The WebDL is configured to work as a data logger by default. Data can be stored from weeks to decades dependant on the version of the WebDL. The data is averaged and stored accordingly to the applied configuration. The latest data is always sent automatically to a specified FTP server by default. But it is also possible to connect to the WebDL as an FTP client and get the data. So the WebDL supports push and pull of data!

6.3.2 Direct Data mode

The WebDL is configured to send its data directly via TCP/IP. This means that there is no data logger, no averaging and no storage of data. The direct data is generated every few seconds. To get this data connect to port 3000 of the network WebDL! (eg. by means of putty). Of course it is also possible to use a 3rd party virtual comport software which links to this port.

6.4 Special tools, equipment, material

For complete configuration of the device an additional Laptop or Desktop-PC with network capability is required.

6.5 Placing in service

The device (re)starts automatically after power is (re-) established.

6.6 Aligning, setting up

6.6.1 Assigning an IP address via DHCP

The WebDL is configured to receive its IP address from a DHCP server by default. So, all necessary configuration is then done automatically, which is considered the easiest way. You just have to find out which IP address has been assigned to your WebDL. You can do this by having a look onto the DHCP server, or you can search for the (unique) MAC address, which is labeled on the WebDL, by means of a MAC scanner software. DHCP is the recommended mode.

6.6.2 Assigning an IP address manually

If you want to do the network configuration of the WebDL manually, then you have to stick to the default IP address first.

If the IP address can not be achieved from a DHCP server, the WebDL will **fallback to the following IP: 192.168.0.90**. (Subnet mask: 255.255.255.0). (This takes some time!)

If you have a DHCP server available in your network, you can force the fallback by directly connecting to your PC by means of a cross link Ethernet cable! In this case it is important to have all the network cables connected before connecting the power cable.

For further configuration you need to set the IP of your PC to an IP address within the default range of the WebDL, e.g.: 192.168.0.1 (Subnet mask: 255.255.255.0).

In manual mode some, maybe necessary settings like DNS entries are not done automatically. So, if these settings are needed it is necessary to do them manually too!

If there are troubles to connect to the WebDL, it is always possible to tell your client to link a specific MAC address to a specific IP address. When using Windows as OS you do that by means of the “arp” command.

(eg.: `arp -s 192.168.0.111 00-aa-bb-cc-dd-ee`)

6.7 Operating

6.7.1 Basic configuration

After assigning an IP address, you can continue with adapting the configuration of the WebDL. This mode is configured by default, if not otherwise specified in the order!

Therefore open your favorite browser and go to the assigned IP address. In the following example it is 192.168.0.90.

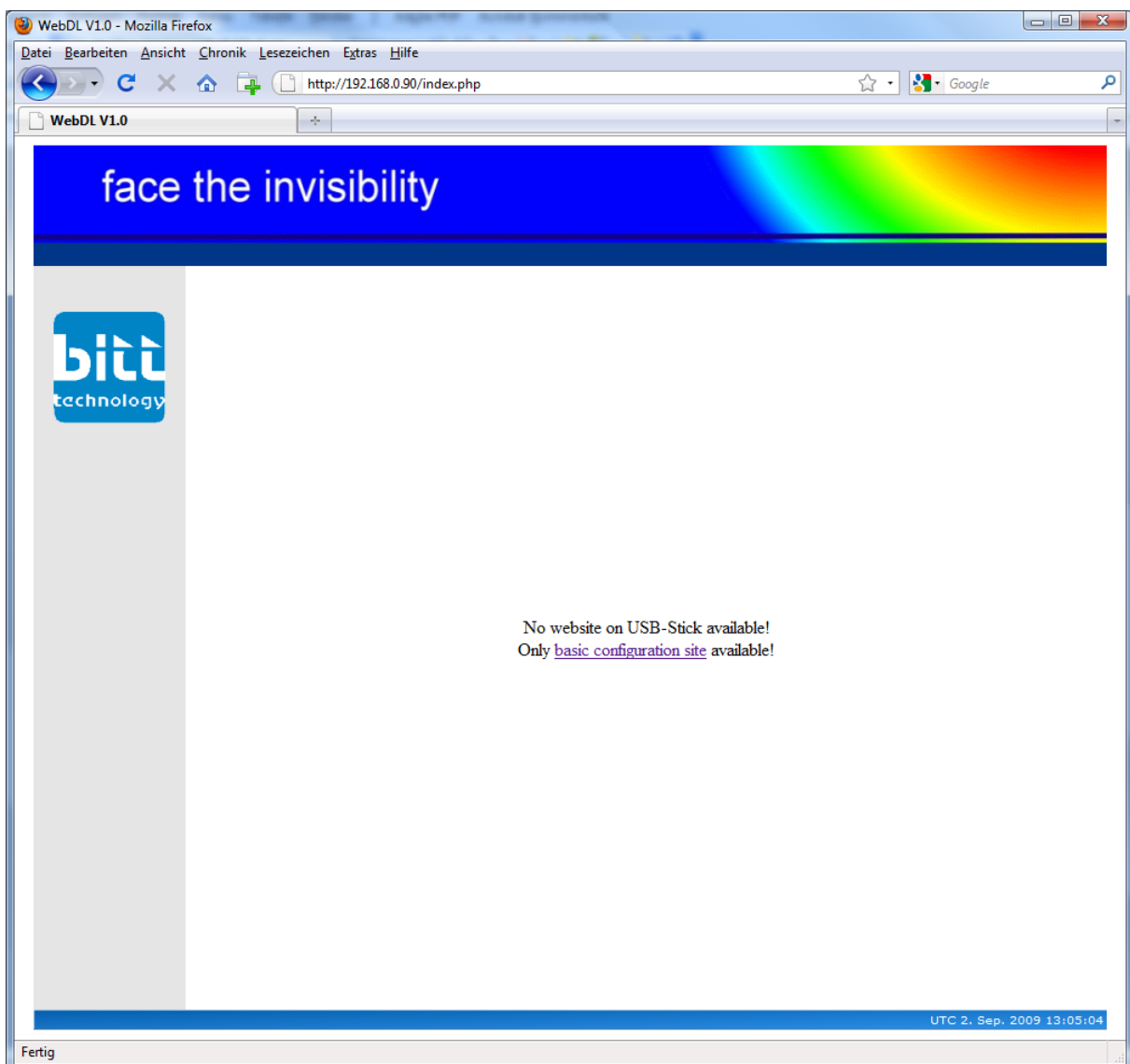

Because only the configuration site is available, you will get the screen above. Click on "basic configuration site". And enter the user credentials in the appearing box.

The default username is “root” and the default password is “Hebitt”. Please note that Linux is case sensitive.

The next screen shows you the basic configuration screen. Starting from here it is possible to edit the most important configuration files as well as to browse the full file system. So please be careful which files you edit. A mistake can lead to serious problems and it may be necessary to send the WebDL to BITT headquarters. So far its safe to click everywhere, but when clicking on a “save file”-button please make sure that you are aware of your actions.

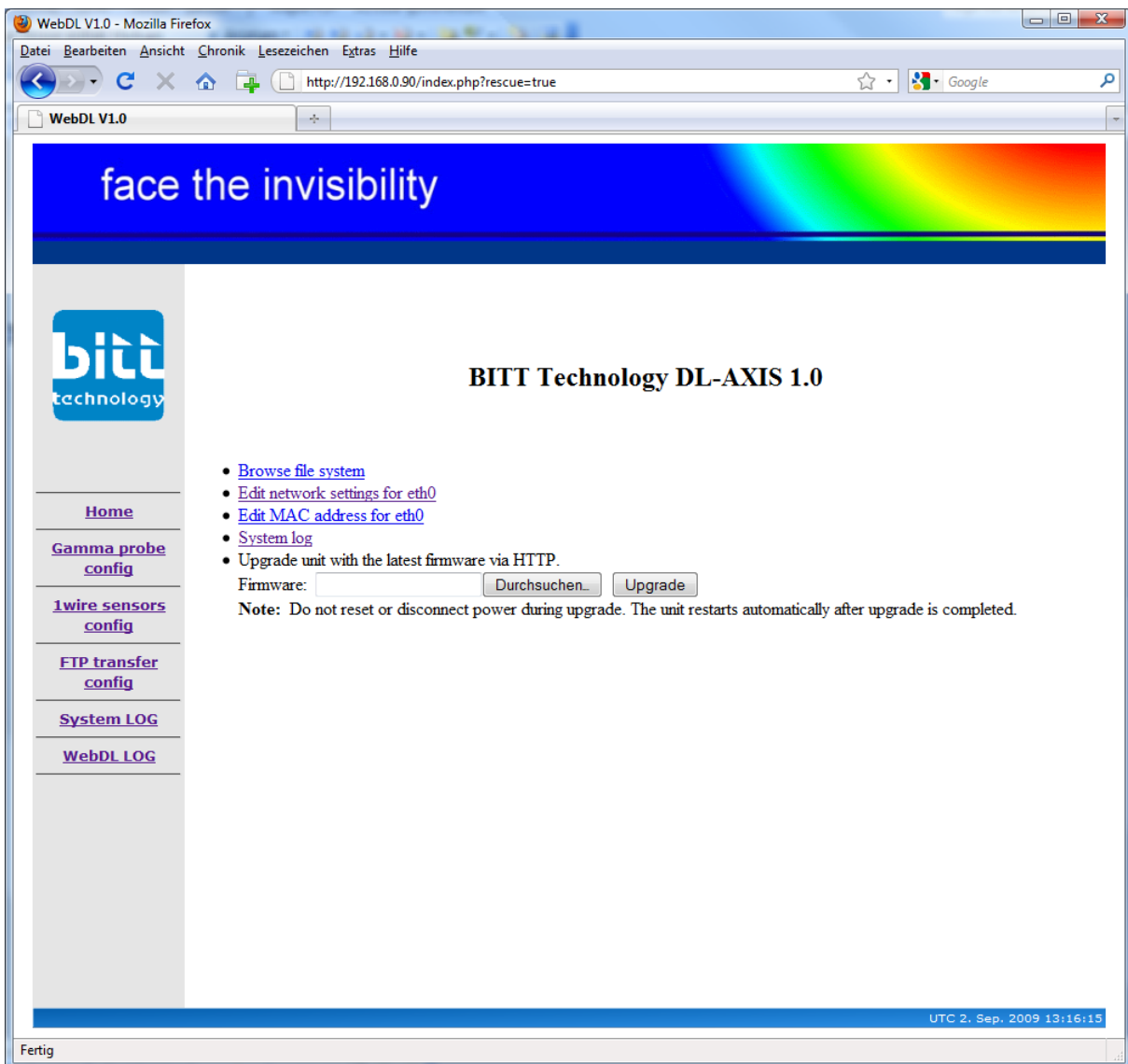

The most important config files have short links on first page or “home”. All these important config files have comments, so that it should be easy to edit them.

6.7.2 Network configuration

To open the network settings, click on “Edit network settings for Eth0”. The most often needed configuration is to switch between “DHCP” and “manual” mode. Therefore just edit the value “BOOTPROTO” accordingly to the comments in the config file. Further important values may be “IP”, “NETMASK”, “BROADCAST” and “GATEWAY”.

The MAC address is unique, if you want to change it anyway use the link “Edit MAC address for eth0”.

6.7.3 Configuration in data logger mode

6.7.3.1 WebDL configuration

The default averaging period is 10 minutes. The corresponding value in the configuration file – click on “Gamma probe config” - is “periodtime”, where the value is given in minutes. The user might want to change the 8 different warning levels as well.

6.7.3.2 FTP Configuration

For changing the FTP push configuration, go to “FTP transfer config”. You might want to change the value “checktime”. For a LAN the default value of 10 seconds is a good choice. For remote applications this might cause a too high amount of data because the connection check is done according to “checktime”. Set this value to eg. 300 seconds in case of a remote application to reduce the amount of data.

Where to send the data is configured by the values with the mask “ftp*”. You need to specify host, username, password and an optional directory. This should be self explaining.

6.7.4 Special direct data operation mode

For setting up this configuration, you need to edit the file “/etc/inittab”. Under Linux this file is something like a startup script. For editing use your favorite browser and use the link “Browse file system”.

You need to comment and uncomment some lines in the inittab. This is done by a leading “#”

Put the data logger program under comment, it should then look like this:

```
#det:3:respawn:/mnt/flash/root/det -d 0
```

Uncomment the software for direct data push, it should look like this:

```
tcpser:3:once:/mnt/flash/root/tcpser
```

Then save the file, wait for completion and reboot the WebDL – use a cold reset!

For changing back to the data logger mode undo the above changes.

After the reboot, the direct data will be provided at port 3000. Please note that only one client can connect to this port. More than one is not supported! In the following examples, this means either Putty or the COM port redirector can be used!

6.7.4.1 View direct data by means of Putty

After the reboot you can try to connect to the WebDL by means of e.g. Putty for viewing live data. Putty is a Telnet/SSH client which can be found on the Internet for free. Enter the IP address as well as the port “3000” and select the “RAW” protocol. You’ll get the output like here.

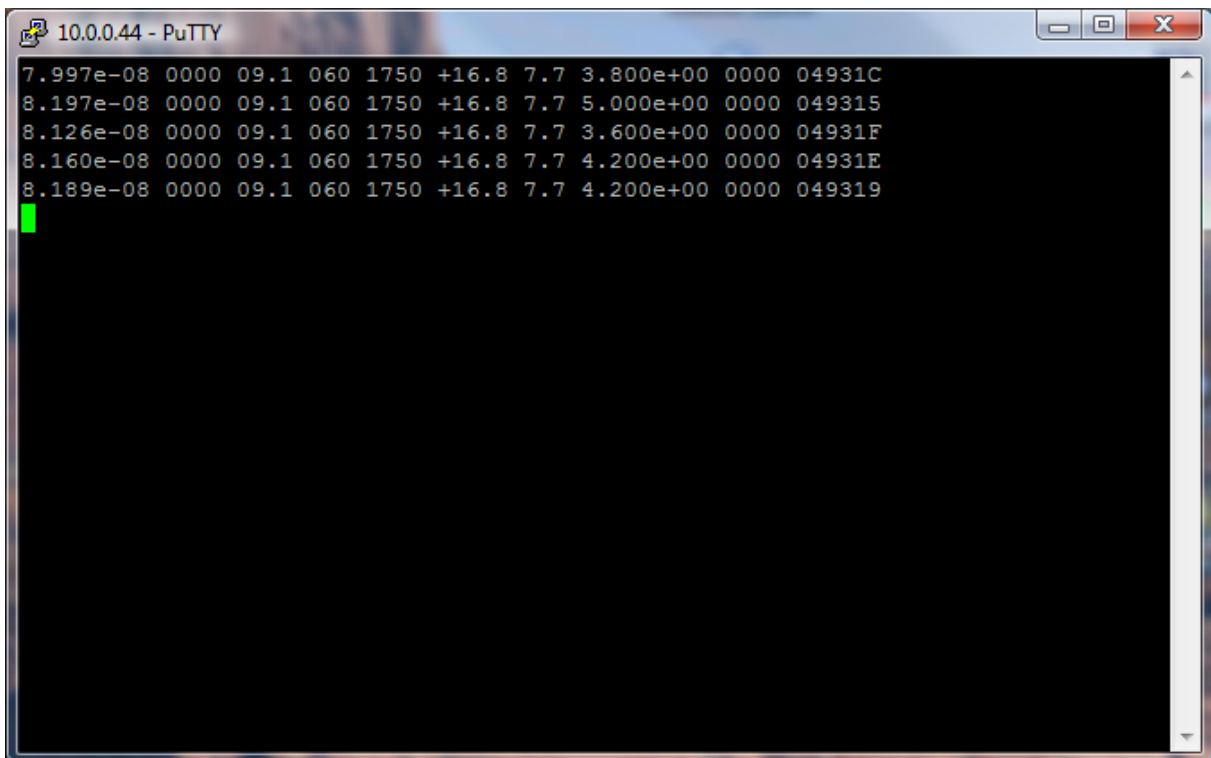

The screenshot shows a PuTTY terminal window titled "10.0.0.44 - PuTTY". The terminal displays five lines of raw data output in a fixed-width font. Each line contains a sequence of numerical values and hexadecimal characters. A green cursor is visible at the beginning of the fifth line.

```
7.997e-08 0000 09.1 060 1750 +16.8 7.7 3.800e+00 0000 04931C
8.197e-08 0000 09.1 060 1750 +16.8 7.7 5.000e+00 0000 049315
8.126e-08 0000 09.1 060 1750 +16.8 7.7 3.600e+00 0000 04931F
8.160e-08 0000 09.1 060 1750 +16.8 7.7 4.200e+00 0000 04931E
8.189e-08 0000 09.1 060 1750 +16.8 7.7 4.200e+00 0000 049319
```

The above protocol format is configured by default, its called OSSENS. The description of the format is included in the RS04 manual. The changes to other protocol formats like shown in the RS04 manual are also possible with the WebDL in the direct data mode!

6.7.4.2 View direct data by means of COM port redirect and BITTSENS SL

For doing this you need to install a COM port redirector which is capable of connecting to a TCP socket. And you need to install software which can handle the provided data! In this example BITTSENS SL and the “HW Virtual Serial Port”

software are used. BITTSENS SL can be installed by taking defaults. The com port redirector shell be installed in “standalone mode”. This is a free 3rd party software.

Start the software, select the COM port you want to use. Type the IP of the WebDL and choose port 3000, like shown in the picture below. Then click “create COM”.

After that the screen looks like this:

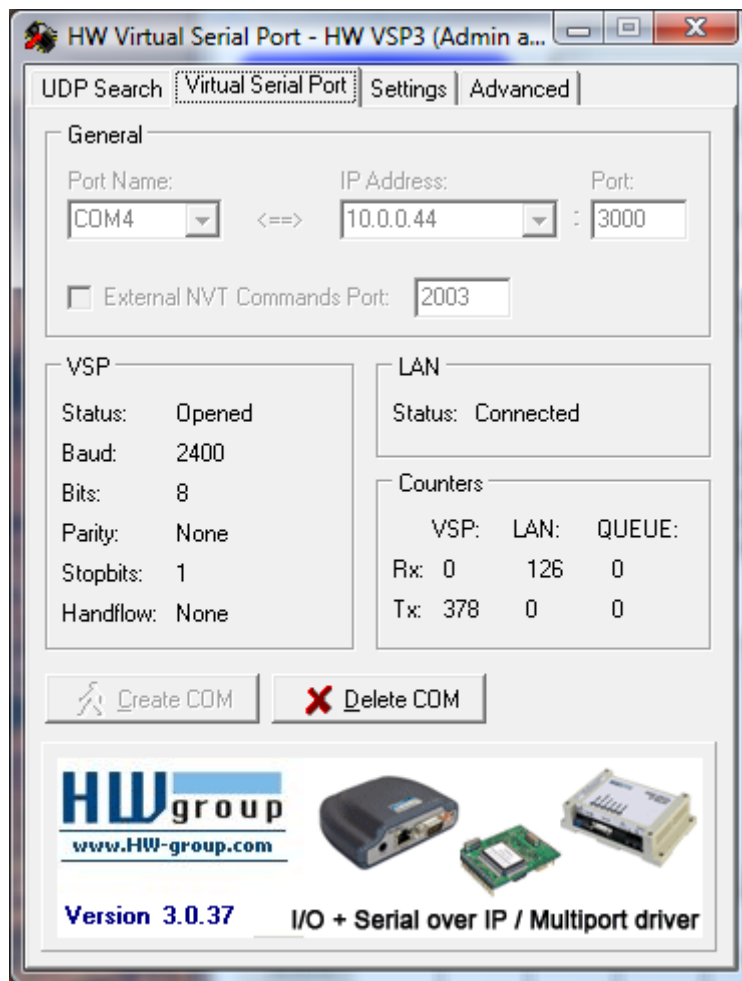

Then start the BITTSENS SL software and choose the same COM port.

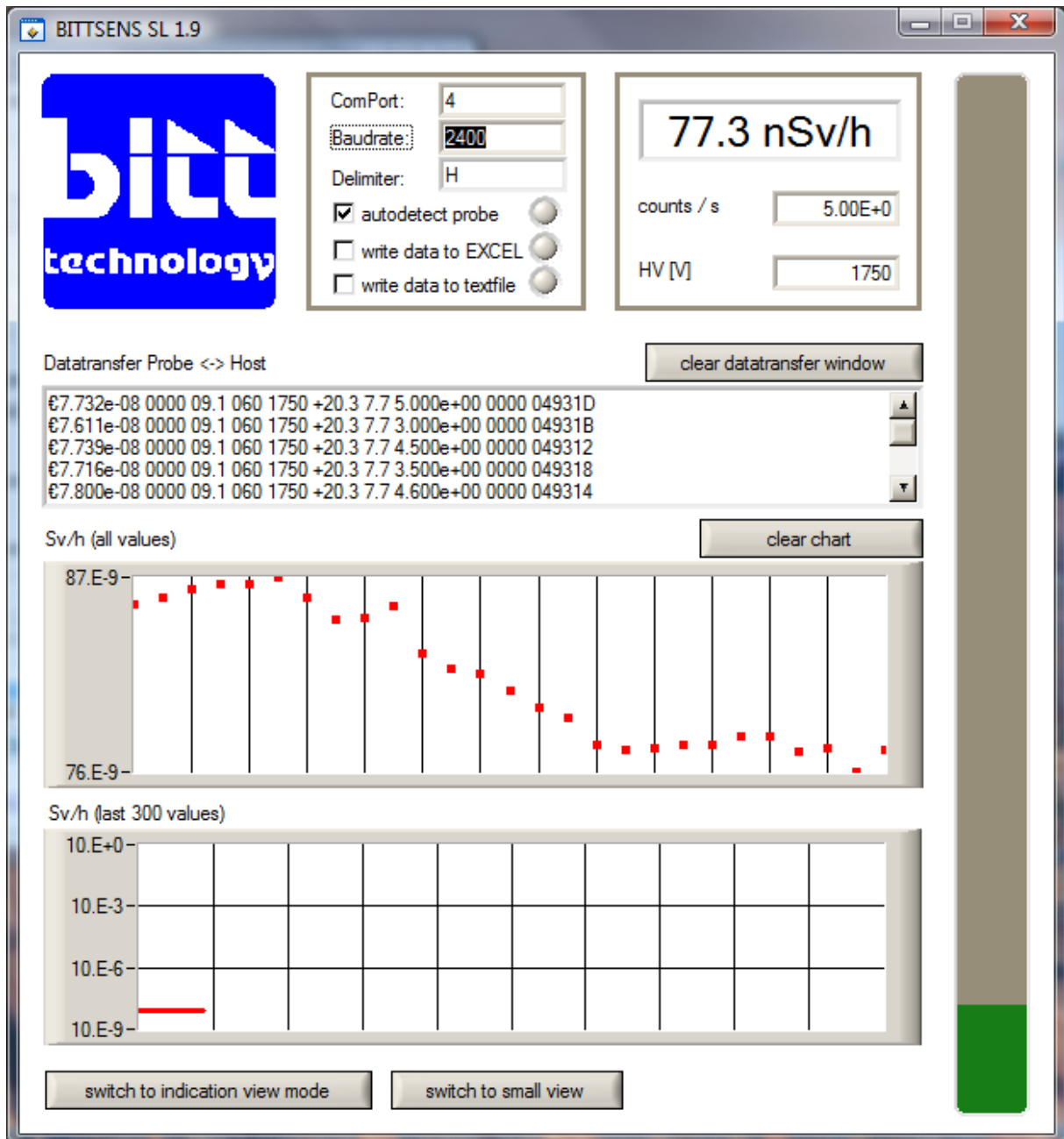

Check the boxes “write data to EXCEL” and/or “write data to text file” if you need averaged and stored data. Writing to EXCEL needs some CPU performance, so if you have an older PC, it might not work fast enough.

Have a look into the BITTSENS SL manual and INI files for further configuration options.

6.7.5 Files and directories in data logger mode

Example of latest averaged dose rate value: /tmp/det.mean.txt

```
2009-09-07 10:20:06
81.6 nSv/h 10 min
Threshold 0
```

Example of latest averaged dose rate 1 min value: /tmp/det.min.txt

```
2009-09-07 10:28:06
83.2 nSv/h 1 min
Threshold 0
```

Example of latest direct dose rate value (not averaged!): /tmp/det.data.txt

```
2009-09-07 10:29:30
81.2 nSv/h
Threshold 0
```

Example of latest status values part 1: /tmp/WEBDL.1wire.main.1.txt

```
2009-09-07 10:26:03
cpu temp: +33.6 C
board temp: +29.0 C
```

Example of latest status values part 2: /tmp/WEBDL.1wire.main.2.txt

```
current: 0.029 A
vdd: 5.0 V
vad: 22.2 V
```

Averaged data to pull, if stored in RAM: /tmp/ftproot. This location is the primary send queue!

Averaged data to pull, if stored in backup: /mnt/flash/ftprootBackup. The data is moved from RAM to the backup if it can not be pushed to the specified FTP server.

6.7.6 File format in data logger mode

File format "DET" (averaged dose rate):

eg.: 015,20090907,112022,10,7.570e-08

Station serial number, date, time, averaging time in minutes, averaged dose rate

File format "BWC" (warning levels):

eg.: 9950,BWC1L038,0,1.20e-07,20090907,111338,0.00e+00,1

Station serial number, some internal status string, warning level, warning level value, date, time, current doserate, warning level trigger (see config file).

File format "state" (status information):

Eg.:9960,BSC1L137,20090907,113042,*0,05,*0,*0,*0,*0,*0,0,0000,0.0,0.000e+00
,0000,0000,20090304,145137,1CB8,0001,20090727,125801,*0,*0,*0,*2,000,0.
00,00.0,+00.0,*0,*0

Station serial number, internal status string, date, time, software state, software version, sensor current state, high voltage state, temperature state, amplifier voltage state, current state, force flag, high voltage value in Volt, amplifier voltage in Volt, sensor count rate in CPS, AD value current, AD value temperature, download time of program, checksum, restart count, date of last CRR, memory state, mains state, battery state, sensor state, sensor current in Ampere, device current in Ampere, battery voltage in Volt, internal temperature, mode flag / rain status, test flag.

File format "dose" (accumulated dose in different warning levels):

eg.:9952,20090727,120921,3.66E-05,3.44E-

07,0.00E+00,0.00E+00,0.00E+00,0.00E+00,0.00E+00,0.00E+00,0.00E+00

Station serial number, date, time, wl0, wl1, wl2, wl3, wl4, wl5, wl6, wl7, wl8

The dose is accumulated since the given timestamp (date + time)

File format “1wire” (status information):

eg.: 023,2009-09-07,11:24:12,+46.3,+39.8,0.078,13.5,5.0

Station serial number, date, time, CPU temperature, board temperature,
current consumption, supply voltage, 5V voltage measurement

For the checksum calculations please look into the RS04 manual.

6.7.7 File Format in Data Logger detailed

File format “DET” (averaged dose rate):

```
|-----|---|-----|---|-----|---|---|---|-----|
| dev#  | k  | yyyymmdd | k  | hhmmss | k  | p  | k  | mv  |
|-----|---|-----|---|-----|---|---|---|-----|
```

dev# = device number	char*3 eg. '001'
k = komma (seperator)	char*1 ',',
yyymmdd = date	char*6
hhmmss = time	char*6
p = period	char*2
average period '01' ... '99'	
mv = mean value	char*8
averaged dose rate for period	

Header format for BSC, BWC

```
|-----|---|-----|
| dev#  | k  | type and length |
|-----|---|-----|
```

dev# = device number	char*3 eg. '001'
k = komma (seperator)	char*1 ',',
type and length	char*8
BSC1L137 for state report	
BWC1L036 for warning level report	

File format "state" (status information):

```
|---|-----|---|-----|---|---|---|---|---|---|---|---|---|---|
| k | yyyymmdd | k | hhmmss | k | v1 | k | v2 | k |           | k | v26 |
|---|-----|---|-----|---|---|---|---|---|---|---|---|---|
```

```
k = komma (seperator)                char*1 ',',
yyyymmdd = date                       char*6
hhmmss   = time                       char*6

v1 = software state                   char*2 obsolete
v2 = software version                 char*2
v3 = current state                    char*2
    'f0' = current ok
    'f1' = current > 150 mA
    'f2' = current < 50 mA
    f = change flag
    '*' = no change, 'C' = changed;

v4 = hv state                         char*2
    'f0' = hv voltage ok
    'f1' = hv voltage > 1800 V
    'f2' = hv voltage < 1600 V

v5 = temperature state                char*2
    'f0' = ok
    'f1' = sensor temperature > 70 degrees Celsius
    'f2' = sensor temperature < - 30 degrees Celsius

v6 = amplifier_voltage_state          char*2
    'f0' = amplifier_voltage ok
    'f1' = amplifier_voltage > 8.5 V
    'f1' = amplifier_voltage < 7.5 V

v7 = current error state              char*2
    'f0' = sensor current channel is in range of sensor pulse channel
    'f1' = sensor current channel out of sensor pulse channel range

v8 = force flag                      char*1 obsolete
v9 = hv [V]                          char*4 '0000' ... '9999'
v10 = amplifier voltage [V]           char*3 '0.0'...'9.9'
v11 = count rate of detector [cps]    char*9 e.g. '4.635E+00'
v12 = AD - value of detector current channel char*4 '0000' ... '1023'
v13 = AD - value of detector temperature char*4 '0000' ... '1023'
v14 = version date [yyymmdd]         char*6
v15 = version time [hhmm]            char*4
v16 = checksum                       char*4 '0000' ... 'FFFF'
v16 = restarts                       char*4 '0000' ... 'FFFF'
v17 = date / time of last CRR message char*11
v18 = memory state                   char*2 obsolete
v19 = mains state                    char*2 not connected !!!
    'f0' = mains operated
    'f1' = battery operated

v20 = battery state                  char*2
    'f0' = battery voltage ok
    'f1' = battery voltage > 15 V
    'f2' = battery voltage < 11 V

v21 = sensor state                   char*2
    'f0' = sensor ok
    'f1' = dose rate > 10 Sv/h
    'f2' = sensor inoperativ

v22 = sensor supply current [mA]     char*3 '000'...'999'
v23 = device supply current [A]      char*4 '0.00'...'9.99'
v24 = battery voltage [V]            char*4 '00.0'...'99.9'
v25 = sensor temperature [degrees Celsius] char*5 '-30.0'...' +70.0'
v26 = mode flag                      char*2         obsolete
v27 = test flag                      char*2         obsolete
```

File format “BWC” (warning levels):

```
|---|----|---|----|---|-----|---|-----|---|----|----|
| k | ln | k | lv | k | yyyymmdd | k | hhmmss | k | mv | k | wt |
|---|----|---|----|---|-----|---|-----|---|----|----|
```

```
k = komma (seperator)                char*1 '\,'
ln = level number                     char*1 '1'...'8'
lv = level value                      char*8 format: d.ddE[+|-]dd
yyyymmdd = date                      char*6
hhmmss = time                        char*4
mv = measured value                  char*8 format: d.ddE[+|-]dd
wt = warning level trigger           char*2
    1: warning level calculated from direct value
    2: warning level calculated from 1 minute value
    3: warning level calculated from 10 minute value
```

6.8 Optional LCD Display

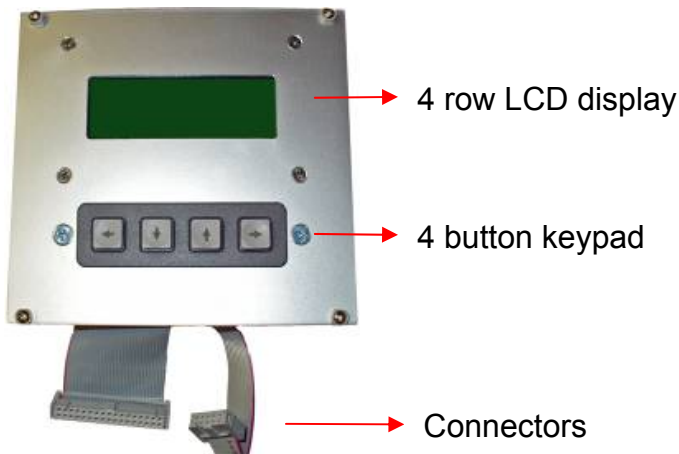

6.8.1 General menu navigation

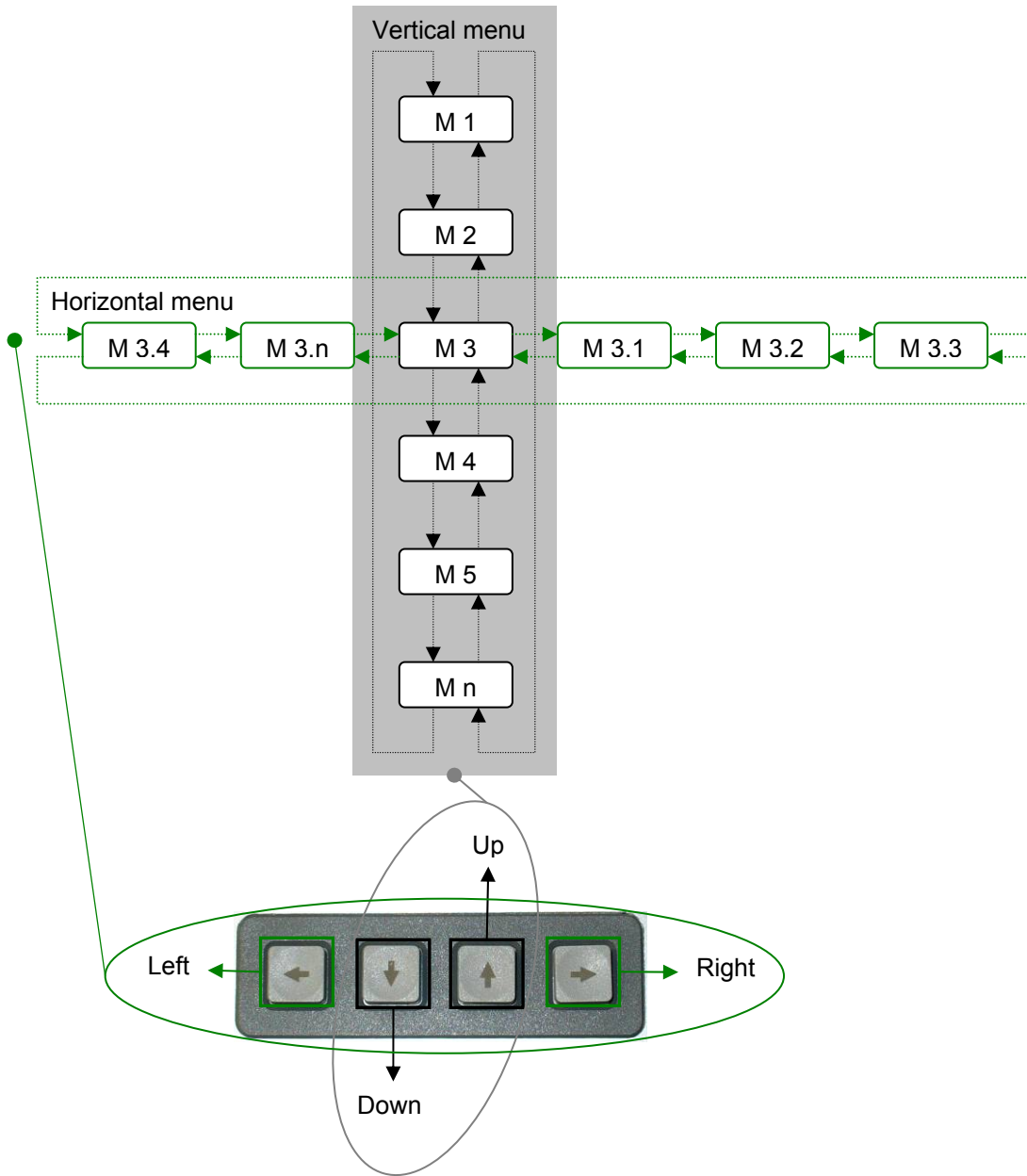

6.8.2 Menu structure part 1

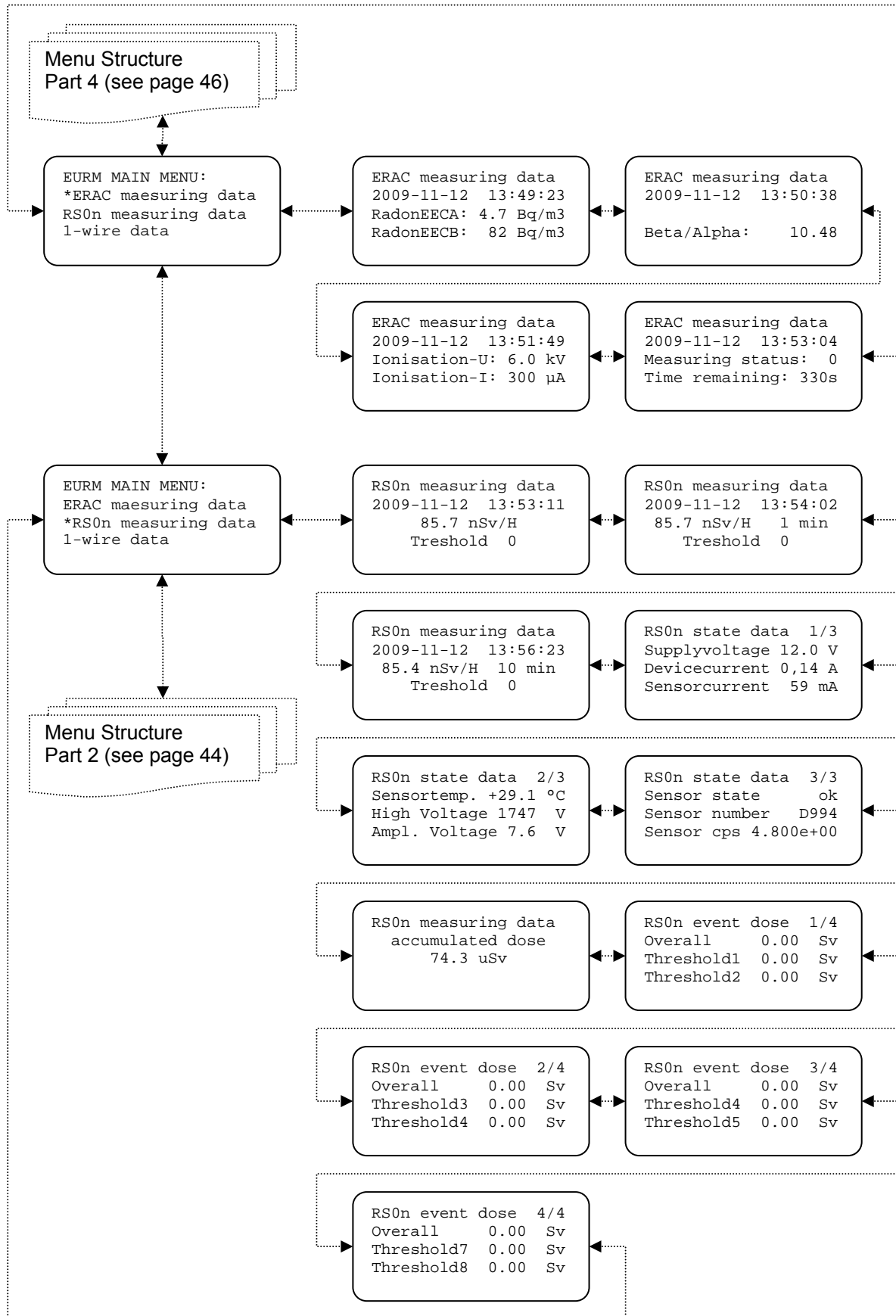

6.8.3 Menu structure part 2

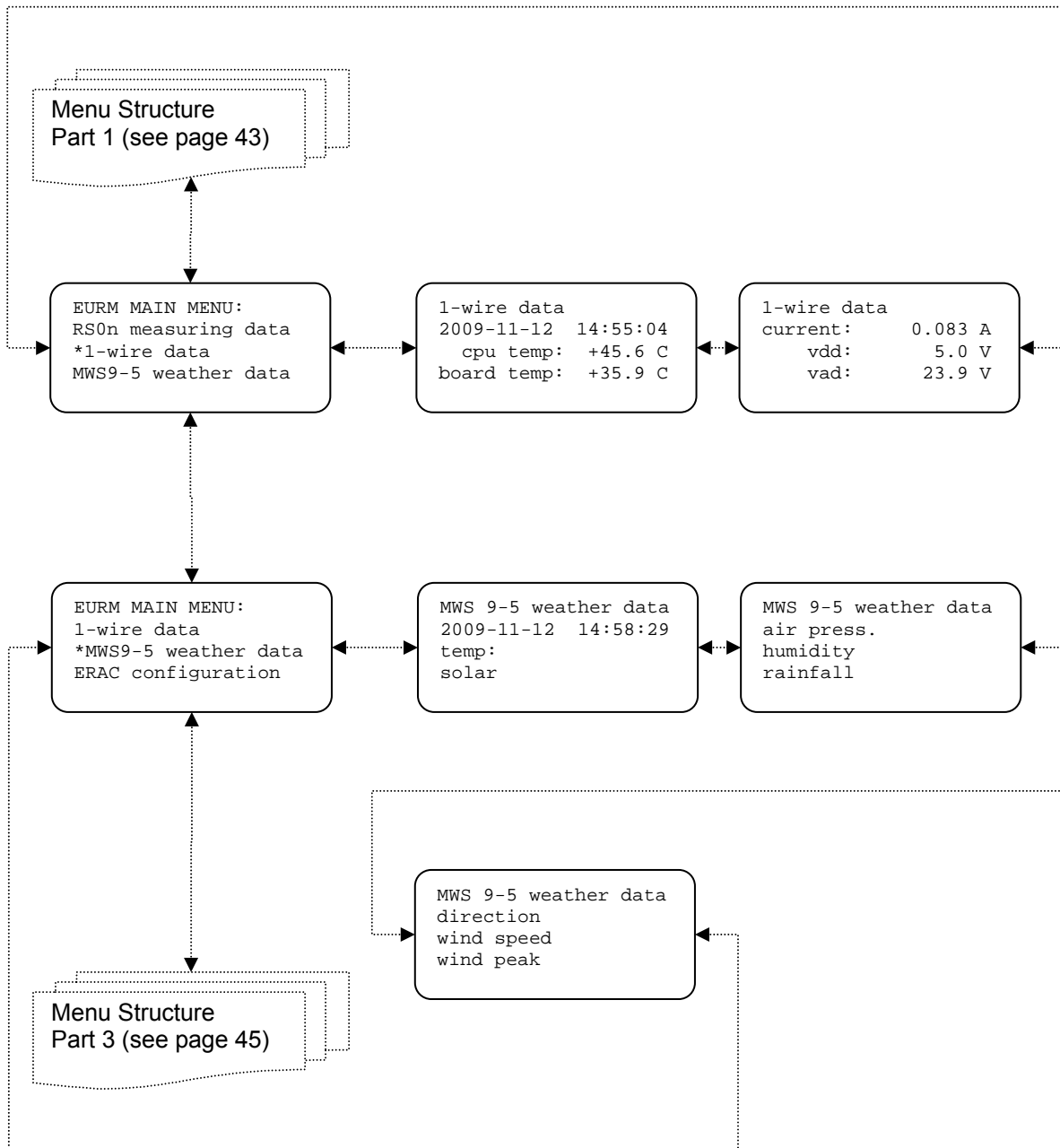

6.8.4 Menu structure part 3

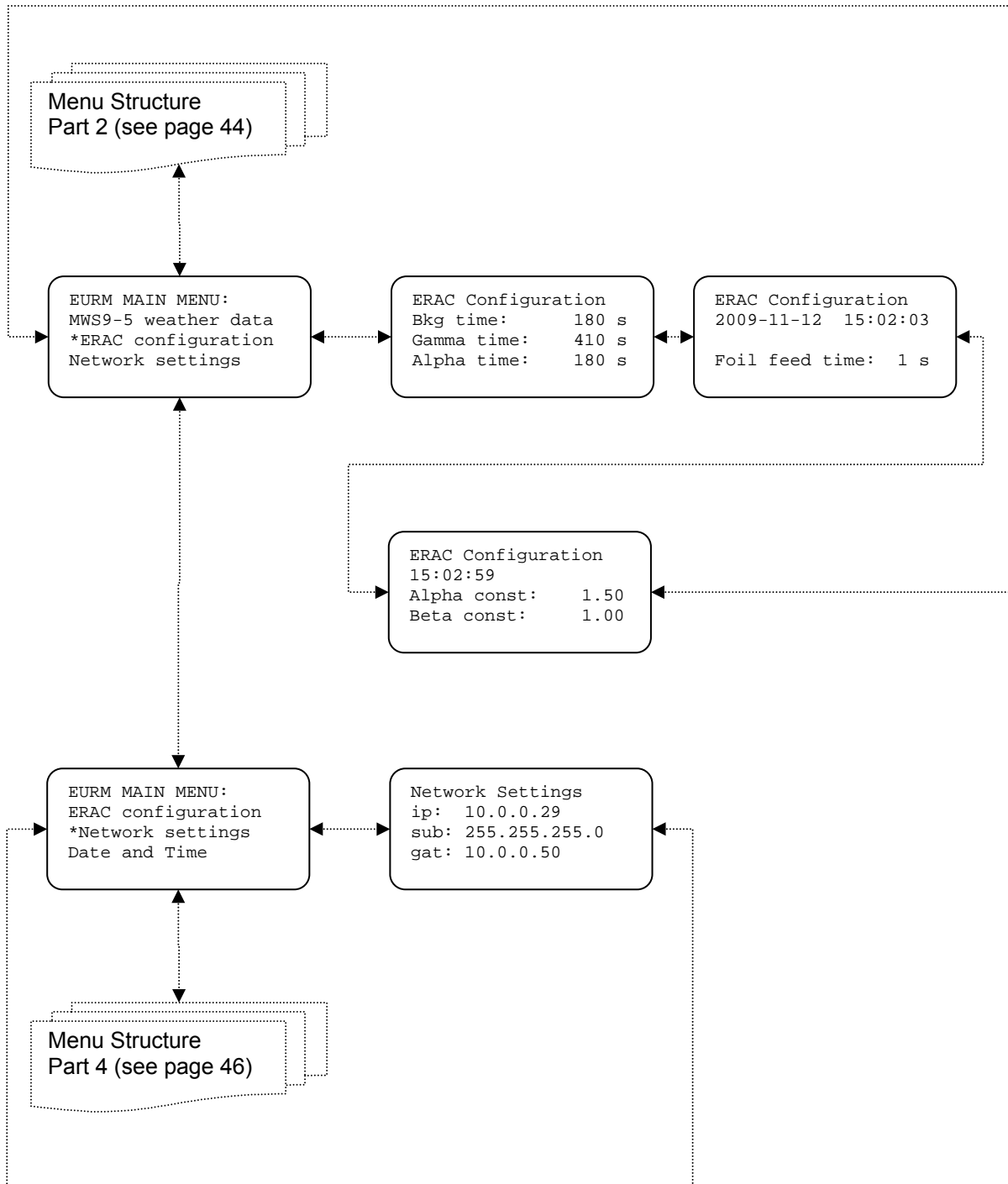

6.8.5 Menu structure part 4

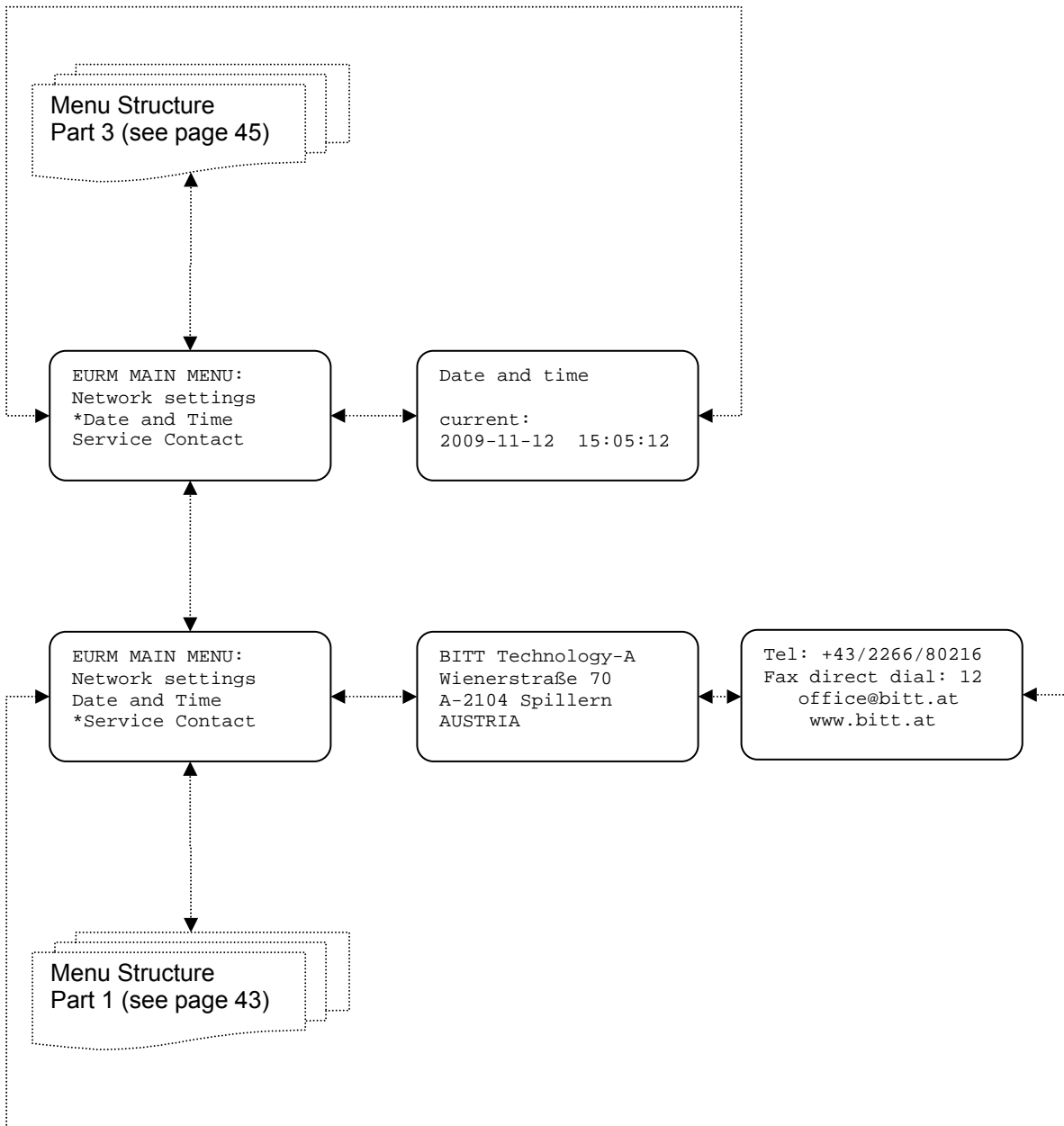

6.9 Instructions on the detection of error states

- By using Display and look for errors
- Use SSH and check the display files
- Use central unit software Scada

7 Troubleshooting

7.1 Service address

BITT Technology
Wienerstraße 70
A-2104 Spillern

Tel.: 0043/ 2266/ 80216
Fax.: 0043/ 2266/ 80216 12

office@bitt.at
www.bitt.at

7.2 Diagnostics and identification of error states

Use debug port of WebDL for checking embedded Linux system messages.

Error message	Possible cause(s)	Rectification
Display without backlight	Screensaver after 60 seconds	Press a key of the 4 button keyboard
Mains LED dark (DDP)	Power failure	Check power line
All LEDs dark	Battery failure	Check battery and DDP

8 Maintenance

8.1 Service address

BITT Technology
Wienerstraße 70
A-2104 Spillern

Tel.: 0043/ 2266/ 80216
Fax.: 0043/ 2266/ 80216 12

office@bitt.at
www.bitt.at

8.2 Definition of maintenance intervals

- Generally if necessary
- Checking battery 1 time a year recommended

8.3 Repair work

Replace damaged devices.

8.4 Spare parts and consumables

- WEBDL board
- 230VAC power supply (optional)
- 4-row LCD Display incl. 4-button keypad (optional)
- Thermal printer (optional)
- Backup battery (optional)
- Deep discharge protection for backup battery (optional)
- Cabinets

Document release

provided by: Martin Frühstück	date: 27.04.2010
for contents: DI Matthias Rötzer	date: 28.04.2010
Released by: Ing. Günter Kemminger	date: 29.04.2010